

• JVC

SERVICE MANUAL

MODEL
R-E3

SYNTHESIZER
STEREO RECEIVER



No. 2601
FEB. 1982

Contents

1. Specifications	1	7-(2) TFC-35 Tuner and Other Functions	
2. Names of Parts and Their Functions	2	Split P.C. Board Ass'y	12
3. Main Parts Location	4	8. R-E3 Schematic Diagram	16
3-(1) Front View	4	9. Packing Materials and Part Numbers	20
3-(2) Rear View	4	10. Accessories List	20
3-(3) Top View	4	11. Parts List with Specified Numbers for Designated Areas	21
4. Exploded View and Part Numbers	5		
5. Tuner Alignment Procedures	6		
5-(1) FM Section	6		
5-(2) AM Section	7		
6. Power Amplifier Idling Current Adjustment Procedure	7		
7. Printed Circuit Board Ass'y and Parts List	8		
7-(1) TXX-399 Main Amp. and Other Functions Split P.C. Board Ass'y	8		

Warning:

When replacing the parts marked with \triangle , be sure to use the designated parts to ensure safety.

1. Specifications

AMPLIFIER SECTION

	IHF	DIN 45 500
RMS Power	: 25 watts per channel, min. RMS, both channels driven, into 8 ohms from 20 Hz to 20 kHz, with no more than 0.08 % total harmonic distortion 30 watts per channel, min. RMS, both channels driven, into 8 ohms at 1 kHz with no more than 0.7 % total harmonic distortion	
Inter Modulation Distortion	: 0.08 % at 25 watts	
Damping Factor	: 40 at 8 ohms, 1 kHz	
Input Sensitivity/ Impedance		
PHONO	: 2.5 mV/47 kohms	
TAPE PLAY, VIDEO/AUX	: 120 mV/40 kohms	
Recording Output/ Load Impedance		
TAPE REC	: 120 mV	
TAPE REC (DIN)	: 30 mV/80 kohms	
Frequency Response		
TAPE PLAY, VIDEO/AUX	: 30 Hz - 40 kHz, +1 dB, -1 dB	
Tone Control		
Bass	: ± 8 dB at 100 Hz	
Treble	: ± 8 dB at 10 kHz	
Loudness Control (Volume control at -40 dB position)	: 7 dB at 50 Hz 4 dB at 10 kHz	
Signal to Noise Ratio	: (Weighted by IHF "A" network)	(To 50 mW power output weighted)
PHONO	: 78 dB (New IHF, Rec out)	60 dB
TAPE PLAY, VIDEO/AUX	: 74 dB (New IHF)	64 dB

FM TUNER SECTION

	IHF	DIN 45 500
Tuning Range	: 87.5 MHz - 108.1 MHz	87.5 MHz - 108.1 MHz (S/N 26 dB)
Usable Sensitivity	: Mono 10.3 dBf	Mono 0.8 μ V/75 Ω Mono 1.6 μ V/300 Ω

	IHF	DIN45 500
50 dB Quieting Sensitivity	: Mono 17.2 dBf (4.0 μ V/300 Ω) Stereo 38.3 dBf (45 μ V/300 Ω)	-
S/N 46 dB Stereo Sensitivity	: -	Stereo 23 μ V/75 Ω Stereo 46 μ V/300 Ω
Signal to Noise Ratio (at 98 MHz)	: Mono 78 dB Stereo 71 dB (A-net.)	Mono 70 dB Stereo 61 dB (weighted)
Total Harmonic Distortion 1 kHz	: Mono 0.15 % Stereo 0.3 %	Mono 0.15 % Stereo 0.3 %
Frequency Response	: 30 Hz - 12.5 kHz, +0.5 dB, -3 dB	
Capture Ratio	: 1.5 dB	1.0 dB
Alternate Channel Selectivity	: 65 dB, ± 400 kHz	55 dB, ± 300 kHz
Image Response Ratio	: 60 dB at 98 MHz	
IF Response Ratio	: 80 dB at 98 MHz	
Stereo Separation	: 40 dB at 1 kHz	40 dB at 1 kHz

AM TUNER SECTION

	IHF	DIN 45 500
Tuning Range	: 520 - 1610 kHz (channel spacing 10 kHz)	522 - 1611 kHz (channel spacing 9 kHz)
Sensitivity	: 100 μ V at 1000 kHz 300 μ V/m at 1000 kHz	
Signal to Noise Ratio	: 50 dB	
Selectivity	: 40 dB, ± 10 kHz	36 dB, ± 9 kHz
Total Harmonic Distortion	: 0.5 % at 100 mV/m	

DIMENSIONS AND WEIGHT

Dimensions			Net Weight
Height	Width	Depth	
118 mm 4-21/32"	340 mm 13-3/8"	273 mm 10-3/4"	4.6 kg 10.1 lbs

Design and specifications subject to change without notice.

2. Names of Parts and Their Functions

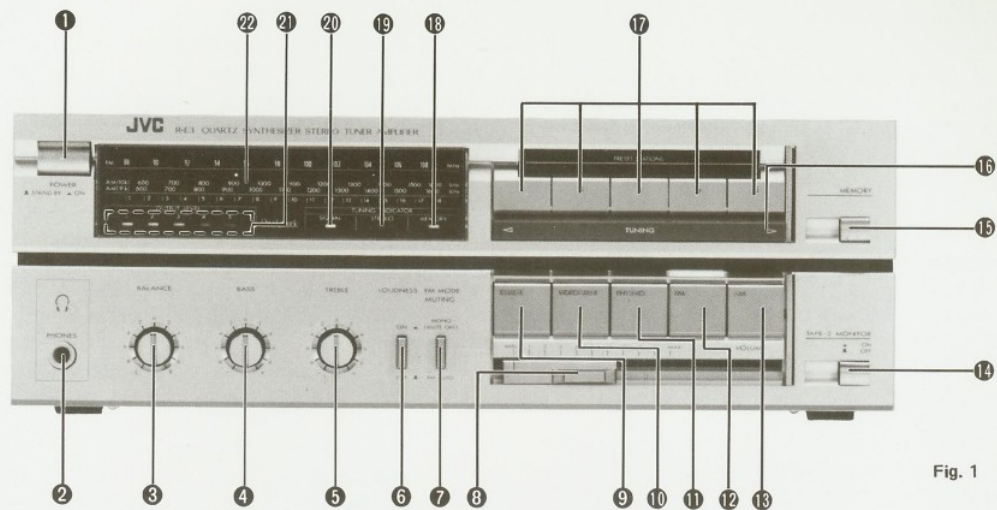

Fig. 1

1 POWER switch

ON: Press to turn the power on. During the first 3 or 4 seconds after the POWER switch is turned on, no sound will be heard until you hear the "click" of the relay operation. This is not due to any defect in the unit, but due to the power protection circuit muting switching noise for speaker protection.

STAND BY: When the power cord is plugged into an AC outlet, the preset stations are not cancelled or altered. The preset data are maintained even in the case of a power failure or when the power cord is disconnected, if the period of non-applied power does not exceed a couple of days.

2 Headphone jack (PHONES)

Plug stereo headphones into this jack for private listening and recording monitoring.

3 BALANCE control

Turn to balance the left and right speakers. When it is fully counterclockwise, only the left channel will be heard, and vice versa.

4 BASS control

Turn clockwise to boost bass response, counterclockwise to decrease bass response.

5 TREBLE control

Turn clockwise to boost treble response, counterclockwise to decrease treble response.

6 LOUDNESS switch

At low volumes, certain tones seem to change. This is not alteration of the sound at lower volumes. Press this switch to compensate for this apparent alteration when you are listening at lower volumes.

7 FM MODE/MUTING switch

This switch is used to select both FM AUTO/MONO mode and FM MUTE ON/OFF mode. These functions are related to each other. When stereo reception is possible, set this switch to FM AUTO (■). When signals are too weak to be received, set to MONO/MUTE OFF (—); in this mode FM muting is not effective.

8 VOLUME control

Slide to the right to increase the volume.

9 TAPE-1 switch

Press to listen to a tape deck connected to the rear panel TAPE-1 terminals. When the TAPE-1 switch is pressed, it is impossible to record from a tape deck connected to the TAPE-1 REC terminals.

10, 11, 12, 13 Source select switches (VIDEO/AUX, PHONO, FM, AM)

VIDEO/AUX: Press to listen to sources connected to the rear panel VIDEO/AUX terminals.

PHONO: Press to listen to records played on a turntable connected to the rear panel PHONO terminals.

FM: Press to switch on the FM tuner section.

AM: Press to switch on the AM tuner section.

Notes:

- When one source is selected by pressing the corresponding switch, the one selected previously in automatically released. To avoid malfunctions, do not press two or more switches simultaneously or release all switches.
- When changing from PHONO, VIDEO/AUX to FM, AM, normally bleeps will be heard; this may not happen, depending on the order in which buttons are pressed.
- Changing over FM ↔ AM, an LED in the dial scale which does not display any channel may light.

14 TAPE-2 MONITOR switch

Press to listen to and to monitor a tape deck connected to the TAPE-2 terminals (—). Press it again (■) to disengage.

Note: This switch should not be pressed to listen to sources other than TAPE-2. Listening to other sources is impossible.

15 MEMORY switch

Press this switch and the memory indicator will light to show that this unit is ready to receive a memory setting. Pressing the station select button while the MEMORY indicator is lit (for about 5 sec.) makes it possible to memorize the station being received. When the MEMORY indicator is not lit, the memory function does not operate.

16 TUNING button

Auto Tuning

Up-scanning button (▶): Press this momentarily to start automatic scanning to higher frequencies. When scanning is taking place, beeps will be heard and the LEDs in the tuning dial will indicate increasing frequencies. When a station is received, scanning stops and the LED lit in the dial scale indicates its frequency. Auto scan tuning will not stop when the station is not strong enough for good reception. When the top frequency in the waveband selected is reached, scanning starts in the opposite direction. If you continue to press the scanning button when the top frequency has been reached, scanning will stop at the top frequency. When this button is held pressed, scanning does not stop even if there are stations.

Down-scanning button (◀): Press momentarily to scan to lower frequencies. Its operation is exactly the same as in up-scanning.

Manual tuning

Manual tuning is used when the station required is too weak to be received by auto tuning. Tap the tuning button to change the frequency in single steps. If the TUNING button is held pressed till a bleep is heard, auto tuning will start.

Note:

When manual tuning is used, it does not automatically reverse the direction of scanning when the upper or lower frequency limit is reached.

17 Station select buttons (PRESET STATIONS)

These buttons are used to select one of the preset stations or to memorize a frequency in a channel. If one of these buttons is pressed after the MEMORY switch 15 has been pressed, the station which is being received will be "Memorized". Each of the station select buttons can be used for one FM station and one AM station. When the MEMORY indicator is not lit, press one of these buttons, a bleep will be heard, to receive the station held in memory.

Notes:

- Do not leave unmemorised preset channels as this may cause mistuning.
- Do not press the MEMORY switch and the preset button at the same time. Be sure to release the MEMORY switch and then press the preset button.
- When storing in memory, a bleep is not heard when the station select button is pressed.

18 MEMORY indicator

When the MEMORY switch is pressed, this MEMORY indicator lights to show that the unit is ready to register the preset station to memory. This indicator will go out automatically in about 5 sec. or when the station select button is pressed.

19 FM STEREO indicator

This LED lights when an FM stereo broadcast is tuned in.

20 SIGNAL indicator

This LED lights when tuned to an FM or AM broadcast.

21 OUTPUT LEVEL indicator

These LEDs indicate the output level.

22 Tuning dial LED

The tuned-in frequency is displayed by this LED.

Notes:

- One LED covers 6 channels in FM (U.S.A. and Canada), covers 24 channels in FM (Europe and other countries), 6 channels in 10 kHz-step AM and 7 channels in 9 kHz-step AM. Therefore, a single LED may correspond to more than one station.
- Both 9 kHz and 10 kHz AM dial scale channel spacing steps are printed on sets for the U.S.A., Canada and some other countries. If your channel spacing steps are 9 kHz, use the 9 kHz tuning dial scale.
- The receivable frequency range for one LED is 800 kHz for FM, 63 kHz (9 kHz channel spacing steps) and 60 kHz (10 kHz channel spacing steps) for AM.

3. Main Parts Location

3-(1) Top View

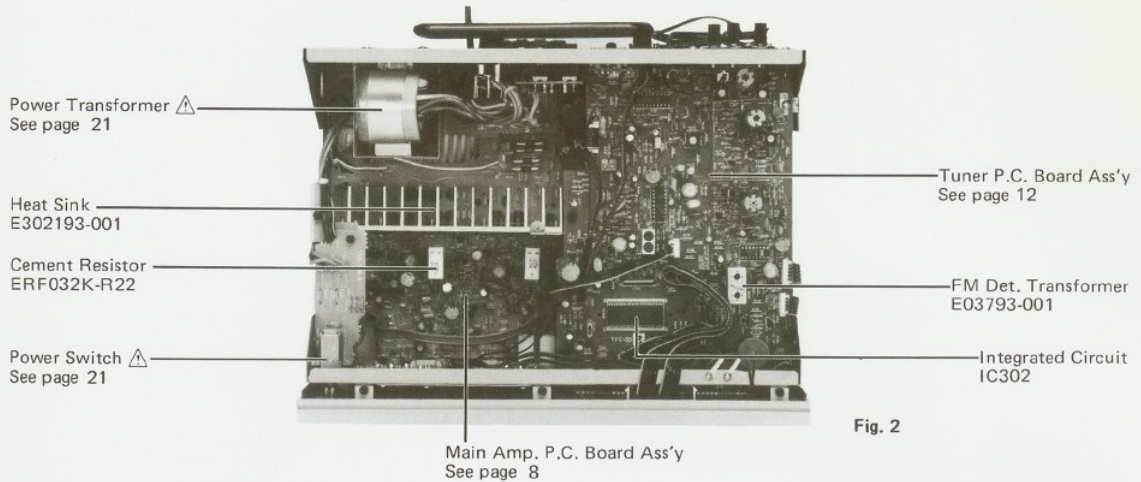

3-(2) Front View

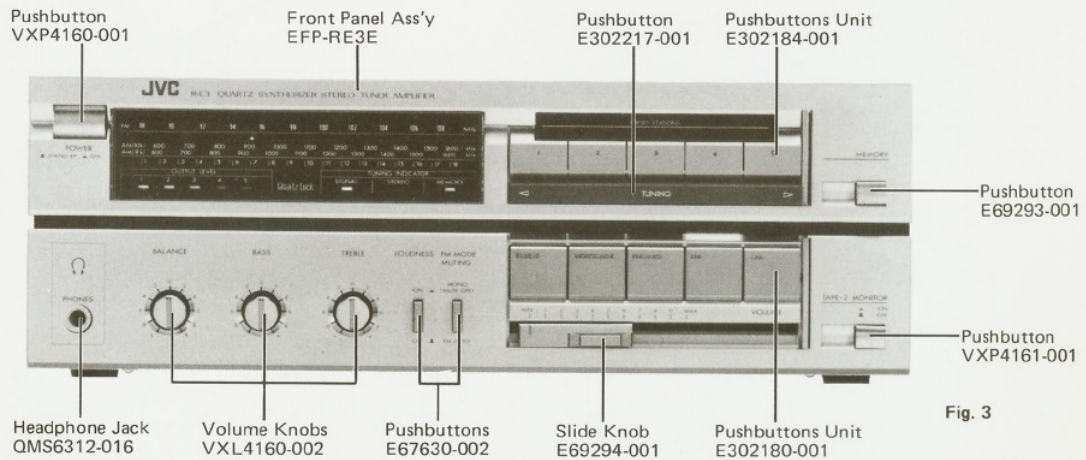

3-(3) Rear View

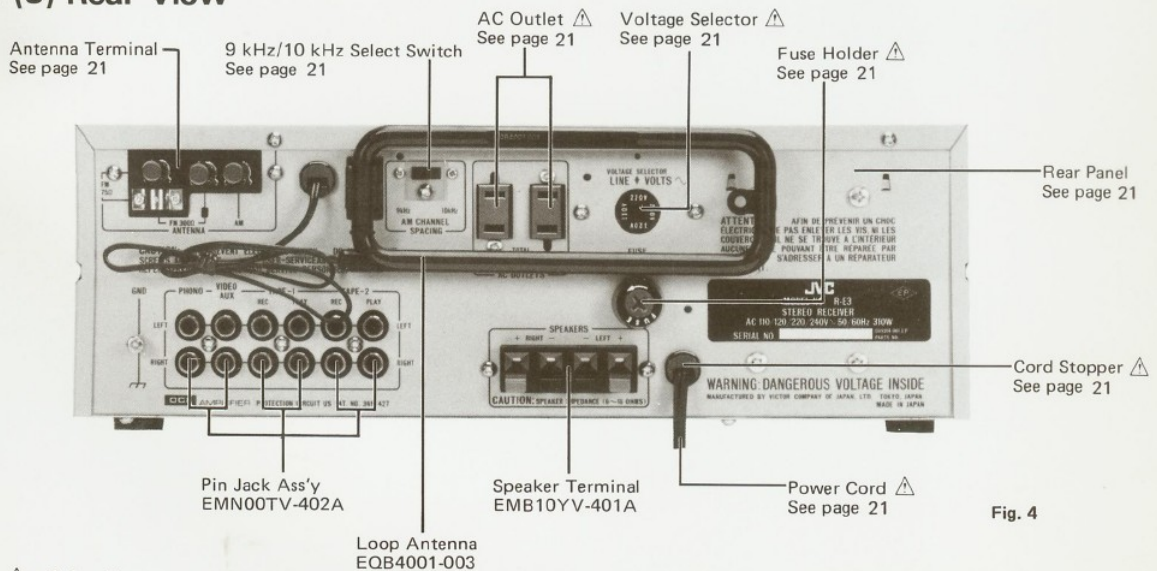

4. Exploded View and Part Numbers

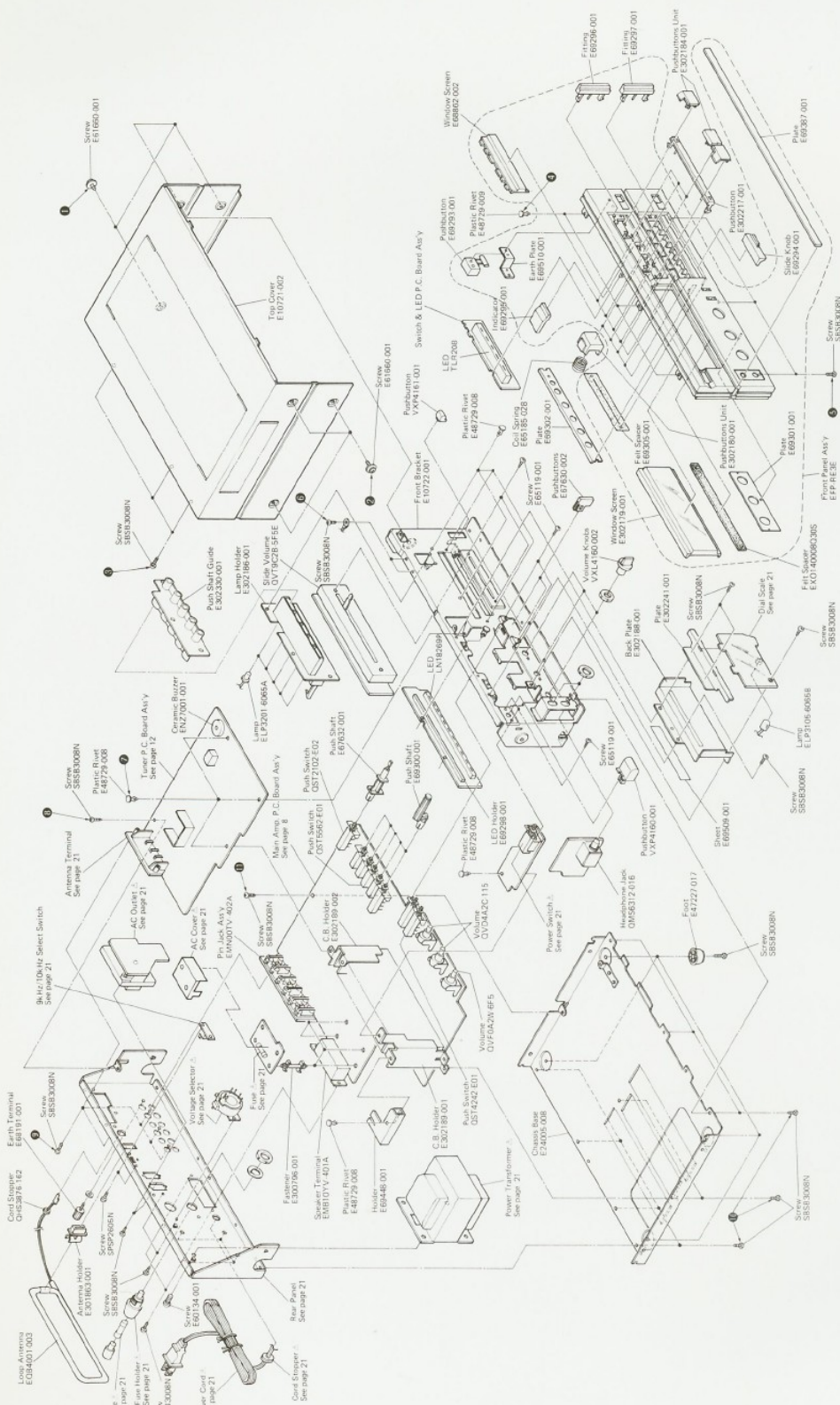

Fig. 5

Removal Procedures

- (1) Front Panel
1. Remove 9 screws ① - ⑨, then remove the top cover.
 2. Take out the slide knob, then remove 3 plastic rivets ④ and 3 screws ⑤.
 3. Remove lag wire mounting screw ⑥ from the front panel, then release the switch & LED board from the catches in the front panel.

(2) Tuner P.C. Board Assy

1. Remove the top cover, then remove 3 plastic rivets ⑦ and screw ⑧ securing the board.
2. Remove 2 screws ⑨ mounting the antenna terminals.

(3) Chassis Base

Check of the amp board is possible by removing the chassis base.
 After removal of the top cover, remove 11 screws ⑩ in the bottom, then remove screw ⑪ securing the amp board, and the chassis base will be released so that the pattern may appear.

5. Tuner Alignment Procedures

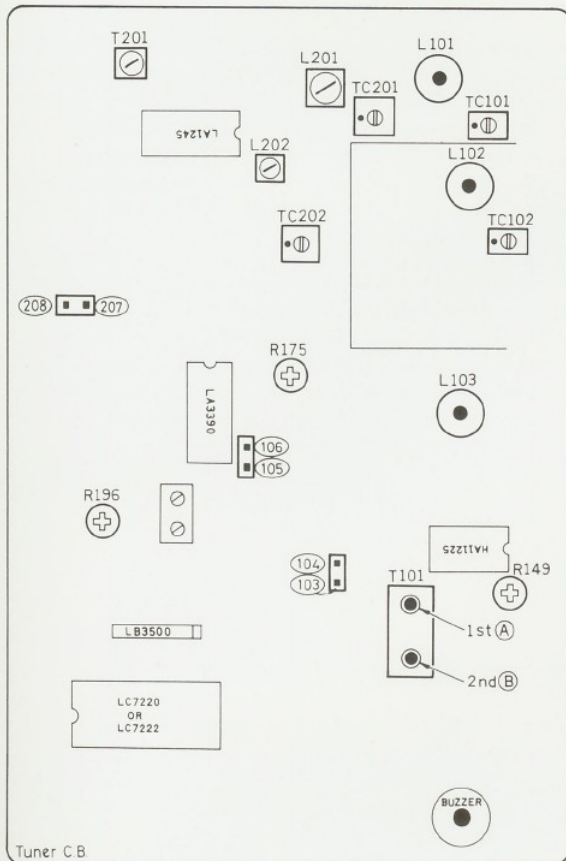

Fig. 6

5-(1) FM Section

Sensitivity

1. Connect an RF generator to 300 Ω antenna terminals on the rear panel through a dummy antenna (FM 75 Ω : 300 Ω PAD).
2. Set the RF generator to 87.5 MHz, a modulation of 1 kHz and a deviation of 75 kHz to provide an input of 1 mV.
3. Connect a VTVM and an oscilloscope to "TAPE-1/REC" jacks on the rear panel.
Note: Set the VTVM to "1 V range" and the oscilloscope to "0.1 V/DIV".
4. Press to "FM" position.
5. Set the frequency display to maximum frequency 108.1 MHz.
6. Connect a DC VTVM between TP-207 and TP-208 (GND), adjust L103 so that the DC VTVM indicates 9.0 V.
7. Set the RF generator's output to 1 mV, connect a DC VTVM between TP-103 and TP-104, adjust the core indicated arrow (A) of T101 for DC VTVM reading of 0 (zero) mV.

8. Set the RF generator to 89.9 MHz and the RF generator's output to 100 mV, set the frequency display to 89.9 MHz by AUTO TUNING (UP or DOWN).
9. Set the RF generator's output to 2 μ V, adjust L101 and L102 until the maximum sensitivity is obtained.
10. Set the RF generator to 105.9 MHz, set the frequency display to 105.9 MHz by AUTO TUNING (UP or DOWN).
11. Set the RF generator's output to 2 μ V, adjust TC101 and TC102 until the maximum sensitivity is obtained.
12. Repeat these high and low frequency adjustment procedures alternately until maximum sensitivity is obtained.

Discriminator and Distortion

1. Connect an RF generator set to 1 kHz modulation and 75 kHz deviation to the antenna terminals on the rear panel through a dummy antenna.
2. Connect an oscilloscope, distortion meter and AC VTVM to the "TAPE-1/REC" jacks on the rear panel.
3. Set the RF generator to 98.1 MHz and output of 1 mV.
4. Set the frequency display to 98.1 MHz by AUTO TUNING (UP or DOWN).
5. Connect a DC VTVM between TP-103 and TP-104.
6. Adjust the core indicated arrow (A) of T101 for DC VTVM reading of 0 (zero) mV.
7. Adjust the core indicated arrow (B) of T101 so that the distortion is minimized at a value less than 0.4 %.
8. Repeat procedures "6" and "7" alternately until minimum distortion and DC VTVM reading of 0 (zero) mV are obtained.

Multiplex and Stereo Separation

Multiplex

1. Set the stereo signal generator as follows: 400 Hz modulation frequency, 7.5 kHz deviation pilot, 67.5 kHz main and sub carriers. Connect its output to an RF generator.
2. Connect the RF generator to the antenna terminals through a dummy antenna.
3. Connect an AC VTVM, an oscilloscope and a distortion meter to the "TAPE-1/REC" jacks on the rear panel.
4. Set the RF generator to 98.1 MHz and output of 1 mV.
5. Set the frequency display to 98.1 MHz by AUTO TUNING (UP or DOWN).
6. Connect a frequency counter and 1 M Ω resistor between TP-105 (GND) and TP-106 (GND).
Note: Use frequency counter with input impedance of more than 1 M Ω .
7. Switch off the pilot signal of stereo modulator.
8. Adjust R175 so that the frequency counter indicates 18.9 kHz (\pm 25 Hz).

Stereo Separation

9. Switch the selector of stereo modulator to left channel modulation.
10. Adjust R196 so that the output of right channel is minimized.
11. Switch the selector of the modulator to right channel modulation.
12. Adjust R196 so that the left channel is minimized.
13. Set R196 to an average, if the separation of left and right channels are different.

5-(2) AM Section

Tracking and Sensitivity

Note 1: () for adjustment frequency of 9 kHz AM channel spacing.

Note 2: AM channel spacing of 10 kHz ... for U.S.A., Canada and U.S. Military Market.

AM channel spacing of 9 kHz ... for Europe, Australia, U.K. and Other Countries.

1. Press to "AM" position.
2. Connect the RF generator to the antenna terminals on the rear panel through a dummy antenna.
3. Connect an AC VTVM and an oscilloscope to the "TAPE-1/REC" jacks on the rear panel.
4. Set the frequency display to minimum frequency 520 kHz (522 kHz). Connect the DC VTVM between TP-207 and TP-208 (GND), adjust L202 for DC VTVM reading of 1.27 V (1.30 V).
5. Set the frequency display to maximum frequency 1610 kHz (1611 kHz). Adjust TC202 for DC VTVM reading of 8.00 V (8.00 V).
6. Repeat procedures "4" and "5" alternately until specified voltage is obtained.
7. Set the RF generator to 600 kHz (603 kHz), a modulation of 400 Hz and modulated 30 %, to provide an output of 90 dB. (100 dB/m)
8. Set the frequency display to 600 kHz (603 kHz) by AUTO TUNING (UP or DOWN).
9. Set the RF generator's output to 40 dB, adjust T201 and the L201 adjusting the coil to maximize the output signal.
10. Set the RF generator to 1400 kHz (1404 kHz), a modulation of 400 Hz and modulated 30 %, to provide an output of 90 dB. (100 dB/m)
11. Set the frequency display to 1400 kHz (1404 kHz) by AUTO TUNING (UP or DOWN).
12. Set the RF generator's output to 40 dB (50 dB/m), adjust trimmer TC201 in the tuning gang so that the output signal is maximized.
13. Repeat these high and low frequency adjustment procedures alternately until maximum sensitivity is obtained.

6. Power Amplifier Idling Current Adjustment Procedure

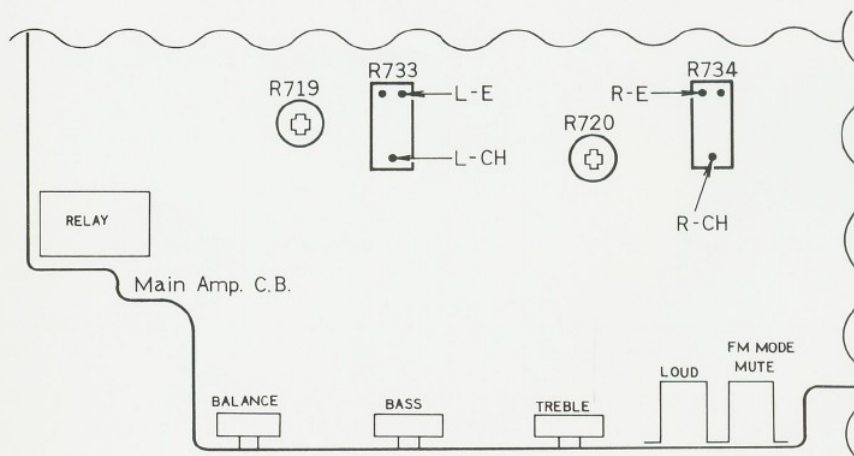

Fig. 7

Precautions:

- (1) Allow the set to warm up at least 5 minutes before connecting a DC VTVM.
- (2) Must keep the heatsinks cooling to prevent overheating and consequent destruction of the semiconductor junction and set the volume control to minimum during these adjustment procedures.

(): for Right channel Adjustment

Procedure:

1. Turn R719 and (R720) fully counterclockwise before the power switch on.
2. Connect a DC VTVM to the Test Point L-CH and L-E (R-CH and R-E).
3. Adjust R719 (R720) for DC VTVM reading of 5 mV.

7. Printed Circuit Board Ass'y and Parts List

7-(1) TXX-399 Main Amp. and Other Functions Split P.C. Board Ass'y



Fig. 8

Transistors

Item No.	Part Number	Rating	Description	
				Maker
Q401	2SC945A (P, Q)		Silicon	Ryosan
Q402	2SC945A (P, Q)		"	"
Q601	2SC458 (D)		"	Hitachi
Q701	2SC1775AV (F)		"	"
Q702	2SC1775AV (F)		"	"
Q703	2SC1775AV (F)		"	"
Q704	2SC1775AV (F)		"	"
Q705	2SA872AV (E)		"	"
Q706	2SA872AV (E)		"	"
Q707	2SA872AV (E)		"	"
Q708	2SA872AV (E)		"	"
Q711	2SA872AV (E)		"	"
Q712	2SA872AV (E)		"	"
Q713	2SA949 (O, Y)		"	Toshiba
Q714	2SA949 (O, Y)		"	"
Q715	2SD636 (Q, R)		"	Matsushita
Q716	2SD636 (Q, R)		"	"
Q717	2SC2235 (O, Y)		"	Toshiba
Q718	2SC2235 (O, Y)		"	"
Q719	2SA965 (O, Y)		"	"
Q720	2SA965 (O, Y)		"	"
Q721	2SD716 (O, R)		"	"
Q722	2SD716 (O, R)		"	"
Q723	2SB686 (O, R)		"	"
Q724	2SB686 (O, R)		"	"
Q725	See page 11		"	Matsushita
Q726	See page 11		"	"
Q801	2SD313V (D, E)		"	Sanyo
Q802	2SC945A (P, Q)		"	Ryosan
Q803	2SD313V (D, E)		"	Sanyo
Q804	2SC945A (P, Q)		"	Ryosan
Q901	2SC1775AV (F)		"	Hitachi
Q902	2SC1775AV (F)		"	"
Q903	2SA733A (P, Q)		"	Ryosan

Integrated Circuits

Item No.	Part Number	Rating	Description	
				Maker
IC401	NJM4558D-D			Dainichi
IC402	NJM4558D-D			"
IC901	TA7317P			Toshiba

Diodes

Item No.	Part Number	Rating	Description	
				Maker
D607	1S2076-31		Silicon	Hitachi
D608	1S2076-31		"	"
D609	1S2076-31		"	"
D801	S3V20F		"	Shindengen
D802	S3V20F		"	"
D803	S3V20F		"	"
D804	S3V20F		"	"
D805	RD15EB3		Zener	Ryosan
D806	RD13EB3		"	"
D807	RD6.2EB3		"	"
D810	1S2076-31		Silicon	Hitachi
D811	RD5.1EB2		Zener	Ryosan
D812	1S2076-31		Silicon	Hitachi
D901	1S2076-31		"	"
D902	1S2076-31		"	"

Coils

Item No.	Part Number	Rating	Description
L701	Y00087-002		Coil
L702	Y00087-002		"

Capacitors

Item No.	Part Number	Rating		Description
C401	QCF31HP-223	0.022 μ F	50 V	Ceramic
C403	QET61HM-105	1 μ F	"	Electrolytic
C404	QET61HM-105	1 μ F	"	"
C405	QCY31HK-182	1800 pF	"	Ceramic
C406	QCY31HK-182	1800 pF	"	"
C407	QCY31HK-682	6800 pF	"	"
C408	QCY31HK-682	6800 pF	"	"
C409	QCS31HJ-101	100 pF	"	"
C410	QCS31HJ-101	100 pF	"	"
C411	QEB41EM-224	0.22 μ F	25 V	Electrolytic
C412	QEB41EM-224	"	"	"
C413	QET61EM-106	10 μ F	"	"
C414	QET61EM-106	"	"	"
C415	See page 11	330 pF	50 V	Ceramic
C416	See page 11	"	"	"
C421	QFM31HK-473	0.047 μ F	"	Mylar
C422	QET61EM-106	10 μ F	25 V	Electrolytic
C423	QET61EM-106	"	"	"
C424	QET61EM-106	"	"	"
C425	QCS31HJ-100	10 pF	50 V	Ceramic
C426	QCS31HJ-100	"	"	"
C427	QET61HM-225	2.2 μ F	"	Electrolytic
C428	QET61HM-225	"	"	"
C429	QET61HM-225	"	"	"
C430	QET61HM-225	"	"	"
C431	QCS31HJ-331	330 pF	"	Ceramic
C432	QCS31HJ-331	"	"	"
C433	QFM31HK-183	0.018 μ F	"	Mylar
C434	QFM31HK-183	"	"	"
C453	QCF31HP-223	0.022 μ F	"	Ceramic
C455	QCF31HP-473	0.047 μ F	"	"
C501	QFM31HK-333	0.033 μ F	"	Mylar
C502	QFM31HK-333	"	"	"
C503	QEZ0046-224	0.22 μ F	"	Electrolytic
C504	QEZ0046-224	"	"	"
C505	QFM31HK-182	1800 pF	50 V	Mylar
C506	QFM31HK-182	"	"	"
C507	QFM31HK-183	0.018 μ F	"	"
C508	QFM31HK-183	"	"	"
C509	QET61HM-475	4.7 μ F	"	Electrolytic
C510	QET61HM-475	"	"	"
C601	QET61HM-475	"	"	"
C701	QET61HM-225	2.2 μ F	"	"
C702	QET61HM-225	"	"	"
C703	QCS31HJ-101	100 pF	"	Ceramic
C704	QCS31HJ-101	"	"	"
C705	QCS31HJ-220	22 pF	"	"
C706	QCS31HJ-220	"	"	"
C707	QET61CM-476	47 μ F	16 V	Electrolytic
C708	QET61CM-476	"	"	"
C709	QCS31HJ-390	39 pF	50 V	Ceramic
C710	QCS31HJ-390	"	"	"
C711	QFM31HK-103	0.01 μ F	"	Mylar
C712	QFM31HK-103	"	"	"
C713	QET61HM-226	22 μ F	"	Electrolytic
C714	QET61HM-226	"	"	"
C715	QFM31HK-473	0.047 μ F	"	Mylar
C716	QFM31HK-473	"	"	"
C717	QFM31HK-473	"	"	"

Capacitors

Item No.	Part Number	Rating		Description
C718	QFM31HK-473	0.047 μ F	50 V	Mylar
C719	QET51HM-107	100 μ F	"	Electrolytic
C720	QET51HM-107	"	"	"
C721	QCS31HJ-680	68 pF	"	Ceramic
C722	QCS31HJ-680	"	"	"
C723	QCS31HJ-330	33 pF	"	"
C724	QCS31HJ-330	"	"	"
C725	See page 11	1000 pF	"	Mylar
C726	See page 11	"	"	"
C801	QEW81HH-478H	4700 μ F	"	Electrolytic
C802	QEW81HH-478H	"	"	"
C803	QFM32AK-103	0.01 μ F	100 V	Mylar
C804	QFM32AK-103	"	"	"
C805	QFM32AK-104	0.1 μ F	"	"
C806	QET51CM-227	220 μ F	16 V	Electrolytic
C807	QCF31HP-103	0.01 μ F	50 V	Ceramic
C808	QET51CM-107	100 μ F	16 V	Electrolytic
C809	QET51AM-227	220 μ F	10 V	"
C811	QET61AM-476	47 μ F	"	"
C821	QCF31HP-103	0.01 μ F	50 V	Ceramic
C822	QCF31HP-473	0.047 μ F	"	"
C823	QCF31HP-473	"	"	"
C824	QCF31HP-473	"	"	"
C901	QCF31HP-223	0.022 μ F	"	"
C902	QCF31HP-223	"	"	"
C903	QET61HM-226	22 μ F	"	Electrolytic
C904	QET61AM-107	100 μ F	10 V	"
C905	QET61CM-226	22 μ F	16 V	"
C906	QET61HM-105	1 μ F	50 V	"
C907	QFM31HK-102	1000 pF	"	Mylar

Resistors

Item No.	Part Number	Rating		Description
R403	QRD141J-222S	2.2 k Ω	1/4 W	Carbon
R404	QRD141J-222S	"	"	"
R405	QRD141J-563S	56 k Ω	"	"
R406	QRD141J-563S	"	"	"
R407	QRD141J-102S	1 k Ω	"	"
R408	QRD141J-102S	"	"	"
R409	QRD141J-393S	39 k Ω	"	"
R410	QRD141J-393S	"	"	"
R411	QRD141J-474S	470 k Ω	"	"
R412	QRD141J-474S	"	"	"
R413	QRD141J-333S	33 k Ω	"	"
R414	QRD141J-333S	"	"	"
R415	QRD141J-102S	1 k Ω	"	"
R416	QRD141J-102S	"	"	"
R417	QRD141J-221S	220 Ω	"	"
R418	QRD141J-221S	"	"	"
R421	QRD141J-222S	2.2 k Ω	"	"
R422	QRD141J-563S	56 k Ω	"	"
R423	QRD141J-224S	220 k Ω	"	"
R424	QRD141J-224S	"	"	"
R425	QRD141J-222S	2.2 k Ω	"	"
R426	QRD141J-222S	"	"	"
R427	QRD141J-104S	100 k Ω	"	"
R428	QRD141J-104S	"	"	"
R429	QRD141J-104S	"	"	"
R430	QRD141J-102S	1 k Ω	"	"
R431	QRD141J-224S	220 k Ω	"	"
R432	QRD141J-224S	"	"	"
R433	QRD141J-221S	220 Ω	"	"
R434	QRD141J-221S	"	"	"
R435	QRD141J-564S	560 k Ω	"	"
R436	QRD141J-564S	"	"	"
R437	QRD141J-223S	22 k Ω	"	"
R438	QRD141J-223S	"	"	"
R439	QRD141J-683S	68 k Ω	"	"

Resistors

Item No.	Part Number	Rating		Description
R440	QRD141J-683S	68 k Ω	1/4 W	Carbon
R441	QRD141J-332S	3.3 k Ω	"	"
R442	QRD141J-332S	"	"	"
R443	QRG017J-121S	120 Ω	1 W	Oxide Metal Film Δ
R501	QVD4A2C-115	100 k Ω	"	Variable
R502	QVD4A2C-115	"	"	"
R503	QRD141J-123S	12 k Ω	1/4 W	Carbon
R504	QRD141J-123S	"	"	"
R505	QRD141J-182S	1.8 k Ω	"	"
R506	QRD141J-182S	"	"	"
R507	QRD141J-823S	82 k Ω	"	"
R508	QRD141J-823S	"	"	"
R509	QRD141J-182S	1.8 k Ω	"	"
R510	QRD141J-182S	"	"	"
R511	QRD141J-681S	680 Ω	"	"
R512	QRD141J-681S	"	"	"
R513	QRD141J-472S	4.7 k Ω	"	"
R514	QRD141J-472S	"	"	"
R515	QRD141J-562S	5.6 k Ω	"	"
R516	QRD141J-562S	"	"	"
R520	QVF0A2W-6F5	"	"	Variable
R521	QVT9C2B-5F5E	"	"	"
R606	QRD141J-222S	2.2 k Ω	1/4 W	Carbon
R607	QRD141J-222S	2.2 k Ω	"	"
R609	QRD141J-390S	39 Ω	"	"
R611	QRD141J-560S	56 Ω	"	"
R612	QRG027J-122	1.2 k Ω	2 W	Oxide Metal Film Δ
R614	QRD141J-101S	100 Ω	1/4 W	Carbon
R701	QRD141J-222S	2.2 k Ω	"	"
R702	QRD141J-222S	"	"	"
R703	QRD141J-104S	100 k Ω	"	"
R704	QRD141J-104S	"	"	"
R705	QRD149J-101S	100 Ω	"	UNF. Carbon Δ
R706	QRD149J-101S	"	"	"
R707	QRD149J-101S	"	"	"
R708	QRD149J-101S	"	"	"
R709	QRD141J-822S	8.2 k Ω	"	Carbon
R710	QRD141J-822S	"	"	"
R711	QRD141J-561S	560 Ω	"	"
R712	QRD141J-561S	"	"	"
R713	QRD141J-683S	68 k Ω	"	"
R714	QRD141J-683S	"	"	"
R715	QRD141J-272S	2.7 k Ω	"	"
R716	QRD141J-272S	"	"	"
R717	QRD141J-102S	1 k Ω	"	"
R718	QRD141J-102S	"	"	"
R719	QVP4A0B-222	2.2 k Ω	"	Variable
R720	QVP4A0B-222	"	"	"
R721	QRD141J-102S	1 k Ω	1/4 W	Carbon
R722	QRD141J-102S	"	"	"
R723	QRD141J-472S	4.7 k Ω	"	"
R724	QRD141J-472S	"	"	"
R725	QRD141J-182S	1.8 k Ω	"	"
R726	QRD141J-182S	"	"	"
R727	QRD149J-100S	10 Ω	"	UNF. Carbon Δ
R728	QRD149J-100S	"	"	"
R729	QRD149J-100S	"	"	"
R730	QRD149J-100S	"	"	"
R731	QRD149J-271S	270 Ω	"	"
R732	QRD149J-271S	"	"	"
R733	ERF032K-R22	0.22 Ω	3 W	Cement Δ
R734	ERF032K-R22	"	"	"
R737	QRD149J-330S	33 Ω	1/4 W	UNF. Carbon Δ
R738	QRD149J-330S	"	"	"
R739	QRD141J-100S	10 Ω	"	Carbon
R740	QRD141J-100S	"	"	"
R741	QRD149J-470S	47 Ω	"	UNF. Carbon Δ
R742	QRD149J-470S	"	"	"

Δ : Safety Parts

Resistors

Item No.	Part Number	Rating		Description
R743	QRD149J-330S	33 Ω	1/4 W	UNF. Carbon
R744	QRD149J-330S	"	"	"
R803	QRD129J-182	1.8 kΩ	1/2 W	"
R804	QRD149J-101S	100 Ω	1/4 W	"
R805	QRG017J-122S	1.2 kΩ	1 W	Oxide Metal Film [△]
R806	See below	100 Ω	2 W	Oxide Metal Film [△]
R807	QRD129J-222	2.2 kΩ	1/2 W	UNF. Carbon
R808	QRD141J-222S	"	1/4 W	Carbon
R809	QRD141J-563S	56 kΩ	"	"
R810	QRD141J-332S	3.3 kΩ	1/4 W	Carbon
R811	QRD141J-472S	4.7 kΩ	"	"
R813	QRD141J-102S	1 kΩ	"	"
R821	See below	120 Ω	2 W	Oxide Metal Film [△]
R822	See below	"	"	"
R823	See below	"	"	"
R901	QRD141J-222S	2.2 kΩ	1/4 W	Carbon
R902	QRD141J-222S	"	"	"
R903	QRD141J-102S	1 kΩ	"	"
R904	QRD141J-102S	"	"	"
R905	QRD141J-123S	12 kΩ	"	"
R906	QRD141J-123S	"	"	"
R907	QRD141J-103S	10 kΩ	"	"
R908	QRD141J-332S	3.3 kΩ	"	"
R909	QRD141J-222S	2.2 kΩ	"	"
R910	QRD141J-563S	56 kΩ	"	"
R911	QRD141J-183S	18 kΩ	"	"
R912	QRD141J-683S	68 kΩ	"	"
R913	QRD141J-123S	12 kΩ	"	"
R914	QRD141J-184S	180 kΩ	"	"
R915	QRG027J-561	560 Ω	2 W	Oxide Metal Film [△]
R916	QRD141J-273S	27 kΩ	1/4 W	Carbon
R917	QRD141J-223S	22 kΩ	"	"
R918	QRD141J-104S	100 kΩ	"	"
R919	QRD141J-104S	"	"	"
R920	QRD141J-104S	"	"	"
R921	QRD141J-563S	56 kΩ	"	"
R923	QRD141J-472S	4.7 kΩ	"	"
R931	QRD129J-221	220 Ω	1/2 W	UNF. Carbon [△]
R932	QRD129J-221	"	"	"

[△] : Safety Parts

Others

Item No.	Part Number	Rating	Description
	See below		Circuit Board
	E302186-001		Lamp Holder
	E302189-001		CB Holder
	E302189-002		"
	E67601-001		Screw Assy
	SBSB3008Z		Tapping Screw
	SBSE3012Z		"
	E302193-001		Heat-Sink
	E60171-003		"
	E61537-005		"
	E65396-001		Earth Plate
J401	QMS6311-005		Microphone Jack
J901	QMS6312-016		Headphones Jack
S401	QST5562-E01		Push Switch
S402	QST2102-E02		"
S403	QST4242-E01		"
PL401	ELP3201-6065A		Lamp
PL402	ELP3201-6065A		"
PL403	ELP3201-6065A		"
PL404	ELP3201-6065A		"
PL405	ELP3201-6065A		"
RY901	ESK6D24-213		Relay

Specified Numbers for Designated Areas

Item No.	Description	U.S.A. & Canada	Europe & Australia	West Germany	U.K.	U.S. Military Market & Other Countries
—	Circuit Board	E10730-001	E10730-001	E10730-001	E10730-001BS	E10730-001
Q725, 726	Silicon Transistor	—	2SD636 (Q, R)	2SD636 (Q, R)	2SD636 (Q, R)	—
C415, 416	Ceramic Capacitor	—	—	QCS31HJ-331	—	—
C725, 726	Mylar Capacitor	—	—	QFM31HK-102	—	—
R806	Oxide Metal Film [△]	QRG027J-101	QRG027J-101	QRG027J-101	QRG026J-101	QRG027J-101
R821~823	Oxide Metal Film [△]	QRG027J-121	QRG027J-121	QRG027J-121	QRG026J-121	QRG027J-121

[△] : Safety Parts

7-(2) TFC-35 Tuner and Other Functions Split P.C.Board Ass'y

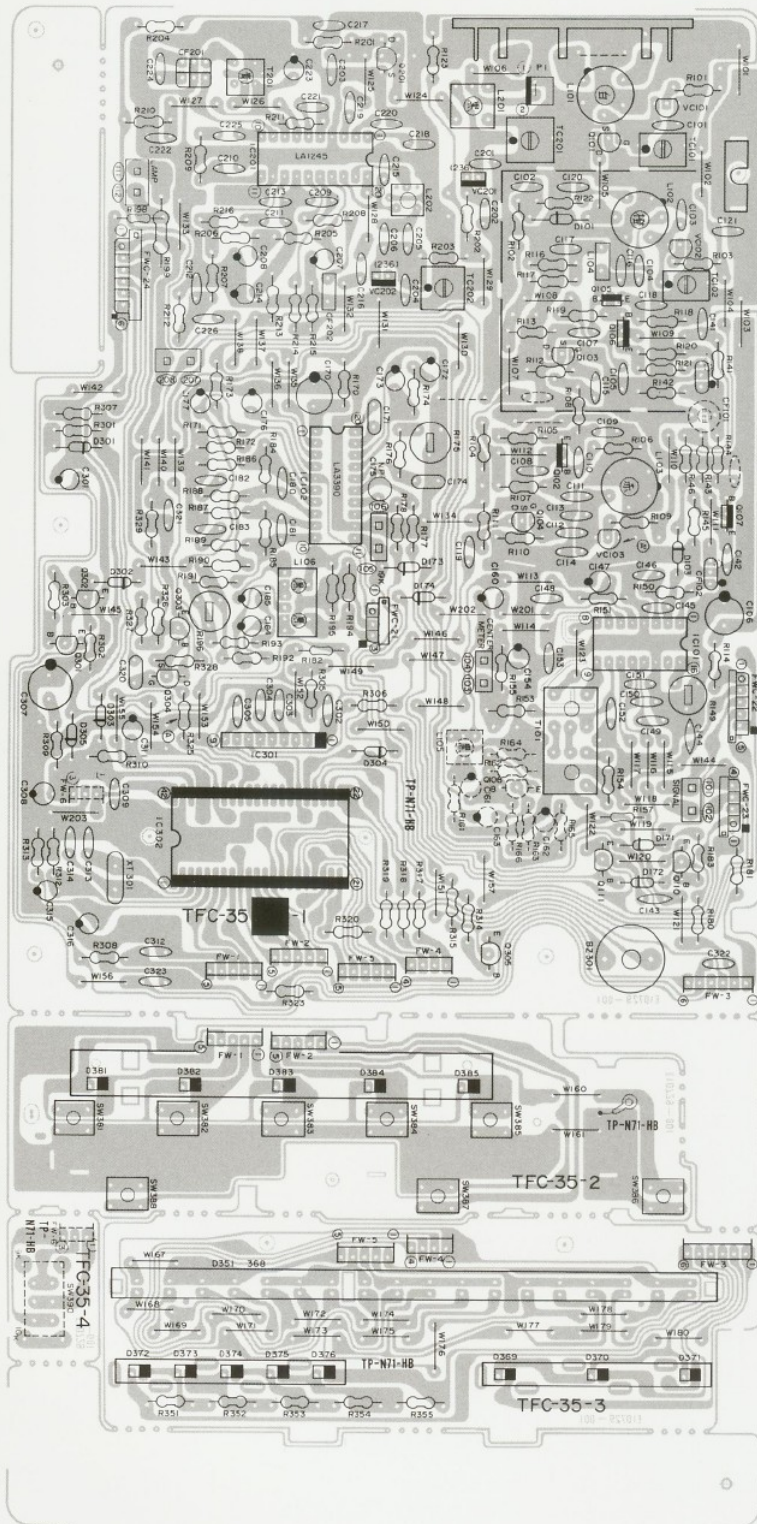

Fig. 9

Transistors

Item No.	Part Number	Rating	Description	
				Maker
Q101	2SK168 (E, F)		F.E.T.	Hitachi
Q102	2SC461 (B, C)		Silicon	"
Q103	2SK168 (E, F)		F.E.T.	"
Q104	2SK61 (GR)		"	Toshiba
Q105	2SC535 (B, C)		Silicon	Hitachi
Q106	2SC461 (B, C)		"	"
Q107	2SC535 (B, C)		"	"
Q108	2SC945A (P, Q)		"	Ryosan
Q110	2SC945A (P, Q)		"	"
Q111	2SC945A (P, Q)		"	"
Q201	2SK105 (F, H)		F.E.T.	"
Q301	2SC945A (P, Q)		Silicon	"
Q302	2SC945A (P, Q)		"	"
Q303	2SC945A (P, Q)		"	"
Q304	2SK336		F.E.T.	Sanyo
Q305	2SC945A (P, Q)		Silicon	Ryosan

Integrated Circuits

Item No.	Part Number	Rating	Description	
				Maker
IC101	HA11225			Hitachi
IC102	LA3390			Sanyo
IC201	LA1245			Sanyo
IC301	LB3500			Hitachi
IC302	See page 15			Sanyo

Diodes

Item No.	Part Number	Rating	Description	
				Maker
D101	1S188FM		Silicon	Sanyo
D103	1S2076-31		"	Hitachi
D171	1S2076-31		"	"
D172	1S2076-31		"	"
D173	1S2076-31		"	"
D174	1S2076-31		"	"
D201	1S2076-31		"	"
D301	1S2076-31		"	"
D302	1S2076-31		"	"
D303	1S2076-31		"	"
D304	1S2076-31		"	"
D305	1S2076-31		"	"
D351	LN18269P		L.E.D.	Matsushita
D369	TLY208		"	Toshiba
D370	TLG208		"	"
D371	TLR208		"	"
D372	TLR208		"	"
D373	TLR208		"	"
D374	TLR208		"	"
D375	TLR208		"	"
D376	TLR208		"	"
D381	TLR205		"	"
D382	TLR205		"	"
D383	TLR205		"	"
D384	TLR205		"	"
D385	TLR205		"	"
VC101	SVC202 (AB)		Varistor	Sanyo
VC102	SVC202 (AB)		"	"
VC103	SVC202 (AB)		"	"
VC201	KV1236Z		"	Toko

Coils and Transformers

Item No.	Part Number	Rating	Description
L101	See page 15		RF Coil
L102	See page 15		"
L103	EQR2406-002		"
L104	EQL3001-1R5KY		Inductor
L105	EQF0102-001		RF Coil
L106	EQF0101-002		"
L201	EQR1110-001		"
L202	ERR1207-001		"
L203	EQL3001-102KY		Inductor
T101	E03793-001		FM DET Transformer
T201	EQT1021-001		I.F. Transformer

Capacitors

Item No.	Part Number	Rating		Description
C102	QCF31HP-103	0.01 μ F	50 V	Ceramic
C103	QCS31HJ-5R0	5 pF	"	"
C104	See page 15	"	"	"
C105	QCF31HP-223	0.022 μ F	"	"
C106	QET51CM-227H	220 μ F	16 V	Electrolytic
C107	QCS31HJ-4R0	4 pF	50 V	Ceramic
C108	QCF31HP-223	0.022 μ F	"	"
C109	QCS31HJ-100	10 pF	"	"
C110	QCS31HJ-220	22 pF	"	"
C111	QCS31HJ-7R0	7 pF	"	"
C112	QCS31HJ-2R0	2 pF	"	"
C113	QCT26UT-5R0	5 pF	"	"
C115	QCS31HJ-4R0	4 pF	"	"
C116	QCS31HJ-4R0	4 pF	"	"
C117	QCS31HJ-151	150 pF	"	"
C118	QCF31HP-223	0.022 μ F	"	"
C119	QCY31HK-102	1000 pF	"	"
C120	QCF31HP-103	0.01 μ F	"	"
C121	QCF31HP-223	0.022 μ F	"	"
C141	QCF31HP-223	"	"	"
C142	QCF31HP-223	"	"	"
C143	QCF31HP-223	"	"	"
C145	QCF31HP-223	"	"	"
C146	QCF31HP-223	"	"	"
C147	QET61HM-475	4.7 μ F	"	Electrolytic
C148	See page 15	"	"	Ceramic
C149	QCF31HP-223	0.022 μ F	"	"
C150	QCF31HP-223	"	"	"
C151	QCS31HJ-471	470 pF	"	"
C152	QCF31HP-223	0.022 μ F	"	"
C153	QCF31HP-223	"	"	"
C154	QET61HM-105	1 μ F	"	Electrolytic
C155	QCF31HP-223	0.022 μ F	"	Ceramic
C160	QET61EM-226	22 μ F	25 V	Electrolytic
C161	See page 15	"	"	"
C162	See page 15	10 μ F	16 V	"
C163	See page 15	22 μ F	25 V	"
C170	QET51CM-227H	220 μ F	16 V	"
C171	QFM31HK-473	0.047 μ F	50 V	Mylar
C172	QEB51EM-335	3.3 μ F	25 V	Electrolytic
C173	QEB51EM-225	2.2 μ F	"	LLC Electrolytic
C174	QFP31HJ-102	1000 pF	50 V	Polypropylene
C175	QEZ0046-105	1 μ F	"	N.P. Electrolytic
C176	QET61HM-475	4.7 μ F	"	Electrolytic
C177	QET61HM-105	1 μ F	"	"
C180	See page 15	"	"	Ceramic
C181	See page 15	"	"	"
C182	QCY21HK-103	0.01 μ F	"	"
C183	QCY21HK-103	"	"	"
C184	QET61HM-475	4.7 μ F	"	Electrolytic
C185	QET61HM-475	"	"	"
C201	QCS31HJ-5R0	5 pF	"	Ceramic

Capacitors

Item No.	Part Number	Rating		Description
C202	QCF31HP-223	0.022 μ F	50 V	Ceramic
C203	QCY31HK-102	1000 pF	"	"
C204	QCS31HJ-150	15 pF	"	"
C205	QCS31HJ-221	220 pF	"	"
C206	QCS31HJ-221	220 pF	"	"
C207	QET61HM-475	4.7 μ F	"	Electrolytic
C208	QET61HM-105	1 μ F	"	"
C209	QCF31HP-223	0.022 μ F	"	Ceramic
C210	QCY31HK-102	1000 pF	"	"
C211	QCF31HP-223	0.022 μ F	"	"
C212	QCF31HP-223	"	"	"
C213	QCF31HP-223	"	"	"
C214	QET61CM-476	47 μ F	16 V	Electrolytic
C215	QCF31HP-223	0.022 μ F	50 V	Ceramic
C216	QCF31HP-223	"	"	"
C217	QCF31HP-223	"	"	"
C218	QCY31HK-102	1000 pF	"	"
C219	QCF31HP-223	0.022 μ F	"	"
C220	QCF31HP-223	"	"	"
C221	QCF31HP-223	"	"	"
C222	QCF31HP-223	"	"	"
C223	QET61EM-226	22 μ F	25 V	Electrolytic
C224	QCS31HJ-560	56 pF	50 V	Ceramic
C225	QCF31HP-223	0.022 μ F	"	"
C226	QCF31HP-223	"	"	"
C301	QET61HM-475	4.7 μ F	"	Electrolytic
C302	QCS31HJ-101	100 pF	"	Ceramic
C303	QCY31HK-102	1000 pF	"	"
C304	QCY31HK-102	"	"	"
C305	QCY31HK-102	"	"	"
C307	QET50JM-228H	2200 μ F	6.3 V	Electrolytic
C308	QET61AM-107	100 μ F	10 V	"
C309	QCF31HP-223	0.022 μ F	50 V	Ceramic
C311	QET61HM-474	0.47 μ F	"	Electrolytic
C312	QCF31HP-223	0.022 μ F	"	Ceramic
C313	QCS31HJ-120	12 pF	"	"
C314	QCS31HJ-120	"	"	"
C315	QET61HM-474	0.47 μ F	"	Electrolytic
C316	QET61HM-474	"	"	"
C320	QFM81HK-104	0.1 μ F	"	Mylar
C321	QCF31HP-223	0.022 μ F	"	Ceramic
C322	QCF31HP-223	"	"	"
C323	QCF31HP-223	"	"	"
TC101	QAT2001-001			Trimmer
TC102	QAT2001-001			"
TC201	QAT2001-005			"
TC202	QAT2001-005			"

Resistors

Item No.	Part Number	Rating		Description
R101	QRD141J-473S	47 k Ω	1/4 W	Carbon
R102	QRD141J-221S	220 Ω	"	"
R103	QRD141J-473S	47 k Ω	"	"
R104	QRD141J-471S	470 Ω	"	"
R105	QRD141J-222S	2.2 k Ω	"	"
R106	QRD141J-682S	6.8 k Ω	"	"
R107	QRD141J-103S	10 k Ω	"	"
R108	QRD141J-330S	33 Ω	"	"
R109	QRD141J-392S	3.9 k Ω	"	"
R110	QRD141J-105S	1 M Ω	"	"
R111	QRD141J-101S	100 Ω	"	"
R112	QRD141J-105S	1 M Ω	"	"
R113	QRD141J-471	470 Ω	"	"
R114	See page 15	47 Ω	"	Carbon or Fusible Δ

Resistors

Item No.	Part Number	Rating		Description
R116	QRD141J-472S	4.7 k Ω	1/4 W	Carbon
R117	QRD141J-153S	15 k Ω	"	"
R118	QRD141J-102S	1 k Ω	"	"
R119	QRD141J-102S	1 k Ω	"	"
R120	QRD141J-102S	1 k Ω	"	"
R121	QRD141J-331S	330 Ω	"	"
R122	See page 15	27 Ω	"	"
R123	QRD141J-103S	10 k Ω	"	"
R141	QRD141J-472S	4.7 k Ω	"	"
R142	QRD141J-222S	2.2 k Ω	"	"
R143	QRD141J-331S	330 Ω	"	"
R144	QRD141J-101S	100 Ω	"	"
R145	QRD141J-102S	1 k Ω	"	"
R146	QRD141J-103S	10 k Ω	"	"
R149	QVP4A0B-223	22 k Ω	"	Variable
R150	QRD141J-331S	330 Ω	1/4 W	Carbon
R151	QRD141J-473S	47 k Ω	"	"
R153	See page 15	"	"	"
R154	QRD141J-332S	3.3 k Ω	"	"
R155	QRD141J-271S	270 Ω	"	"
R157	See page 15	47 Ω	"	Carbon or Fusible Δ
R161	See page 15	12 k Ω	"	Carbon
R162	See page 15	82 k Ω	"	"
R163	See page 15	3.9 k Ω	"	"
R164	See page 15	2.2 k Ω	"	"
R165	See page 15	1 k Ω	"	"
R166	See page 15	220 k Ω	"	"
R170	See page 15	33 Ω	"	Carbon or Fusible Δ
R171	QRD141J-474S	470 k Ω	"	Carbon
R172	QRD141J-273S	27 k Ω	"	"
R173	QRD141J-184S	180 k Ω	"	"
R174	QRD141J-102S	1 k Ω	"	"
R175	QVP4A0B-472	4.7 k Ω	"	Variable
R176	QRD141J-103S	10 k Ω	1/4 W	Carbon
R177	QRD141J-104S	100 k Ω	"	"
R178	QRD141J-331S	330 Ω	"	"
R180	QRD141J-103S	10 k Ω	"	"
R181	QRD141J-331S	330 Ω	"	"
R182	QRD141J-103S	10 k Ω	"	"
R183	QRD141J-393S	39 k Ω	"	"
R184	QRD141J-913S	91 k Ω	"	"
R185	QRD141J-913S	"	"	"
R186	QRD141J-274S	270 k Ω	"	"
R187	QRD141J-274S	"	"	"
R188	QRD141J-100S	10 Ω	"	"
R189	QRD141J-100S	"	"	"
R190	QRD141J-102S	1 k Ω	"	"
R191	QRD141J-102S	"	"	"
R192	QRD141J-222S	2.2 k Ω	"	"
R193	QRD141J-222S	"	"	"
R194	QRD141J-682S	6.8 k Ω	"	"
R195	QRD141J-682S	"	"	"
R196	QVP4A0B-473	47 k Ω	"	Variable
R198	QRD141J-100S	10 Ω	1/4 W	Carbon
R199	QRG017J-121S	120 Ω	1 W	Oxide Metal Film Δ
R201	QRD141J-331S	330 Ω	1/4 W	Carbon
R202	QRD141J-103S	10 k Ω	"	"
R203	QRD141J-473S	47 k Ω	"	"
R204	QRD141J-102S	1 k Ω	"	"
R205	QRD141J-103S	10 k Ω	"	"
R206	QRD141J-103S	10 k Ω	"	"
R207	QRD141J-123S	12 k Ω	"	"
R208	QRD141J-820S	82 Ω	"	"
R209	QRD141J-331S	330 Ω	"	"
R210	QRD141J-331S	"	"	"
R211	QRD141J-152S	1.5 k Ω	"	"
R212	QRD141J-332S	3.3 k Ω	"	"
R213	See page 15	47 Ω	"	Carbon or Fusible Δ

Δ : Safety Parts

Resistors

Item No.	Part Number	Rating	Description
R214	QRD141J-472S	4.7 kΩ	1/4 W Carbon
R215	QRD141J-472S	"	"
R216	QRD141J-101S	100 Ω	"
R220	QRD141J-103S	10 kΩ	"
R301	QRD141J-472S	4.7 kΩ	"
R302	QRD141J-223S	22 kΩ	"
R303	QRD141J-104S	100 kΩ	"
R305	QRD141J-823S	82 kΩ	"
R306	QRD141J-472S	4.7 kΩ	"
R307	QRD141J-333S	33 kΩ	"
R308	QRD141J-331S	330 Ω	"
R309	QRD141J-102S	1 kΩ	"
R310	QRD141J-334S	330 kΩ	"
R312	QRD141J-105S	1 MΩ	"
R313	QRD141J-224S	220 kΩ	"
R314	QRD141J-103S	10 kΩ	"
R315	QRD141J-102S	1 kΩ	"
R317	QRD141J-331S	330 Ω	"
R318	QRD141J-331S	"	"
R319	QRD141J-331S	"	"
R320	QRD141J-331S	"	"
R323	QRD141J-331S	"	"
R325	QRD141J-562S	5.6 kΩ	"
R326	QRD141J-103S	10 kΩ	"
R327	QRD141J-333S	33 kΩ	"
R328	QRD141J-102S	1 kΩ	"
R329	QRD141J-472S	4.7 kΩ	"
R330	QRD141J-103S	10 kΩ	"
R351	QRD141J-222S	2.2 kΩ	"
R352	QRD141J-561S	560 Ω	"
R353	QRD141J-331S	330 Ω	"
R354	QRD141J-181S	180 Ω	"
R355	QRD141J-151S	150 Ω	"

Others

Item No.	Part Number	Rating	Description
	QMV5005-002		2P Plug Assy
	E04365-003		3P Socket
	E04365-004		Jumper Socket
	E04365-005		F.W. Socket
	E04365-006		6P Connector
	E67764-002		Terminal Assy
	E10729-001		Circuit Board
	E302185-001		LED Holder
	E69298-001		"
	E65396-001		Earth Plate
BZ301	ENZ7001-001		Shield Cover
CF101	See below		Ceramic Buzzer
CF102	See below		Ceramic Filter
CF201	ECB1545-001		"
CF202	E03613-022		"
SW381	ESP0001-007		Push SW
SW382	ESP0001-007		"
SW383	ESP0001-007		"
SW384	ESP0001-007		"
SW385	ESP0001-007		"
SW386	ESP0001-007		"
SW387	ESP0001-007		"
SW388	ESP0001-007		"
XT301	ECX0007-200KA		X'tal

Specified Numbers for Designated Areas

Item No.	Description	U.S.A. & Canada	Europe & Australia	West Germany	U.K.	U.S. Military Market & Other Countries
IC302	Integrated Circuit	LC7220	LC7222	LC7222	LC7222	LC7222
L101	RF Coil	EQR2306-014	EQR2306-014	EQR2306-016	EQR2306-014	EQR2306-014
L102	RF Coil	EQR2306-004	EQR2306-004	EQR2306-004	EQR2306-004	-
CF101, 102	Ceramic Filter	ECB2123-002R	ECB2118-001R	ECB2118-001R	ECB2118-001R	ECB2123-002R
C104	Ceramic Capacitor	QCS31HJ-5R0	QCS31HJ-5R0	QCS31HJ-3R0	QCS31HJ-5R0	QCS31HJ-5R0
C148	Ceramic Capacitor	QCS31HJ-151	QCS31HJ-151	QCS31HJ-470	QCS31HJ-151	QCS31HJ-151
C161	Electrolytic Capacitor	-	-	QET61EM-226	-	-
C162	Electrolytic Capacitor	-	-	QET61CM-106	-	-
C163	Electrolytic Capacitor	-	-	QET61EM-226	-	-
C180, 181	Ceramic Capacitor	QCY31HK-821	QCY31HJ-561	QCY31HJ-561	QCY31HJ-561	QCY31HK-821
R114	UNF. Fuse Resistor \triangle	QRD149J-470S	QRZ0052-470	QRZ0052-470	QRZ0052-470	QRD149J-470S
R122	Carbon Resistor	QRD141J-270S	QRD141J-270S	-	QRD141J-270S	QRD141J-270S
R153	Carbon Resistor	QRD141J-123S	QRD141J-243S	QRD141J-243S	QRD141J-243S	QRD141J-243S
R157	UNF. Fuse Resistor \triangle	QRD149J-470S	QRZ0052-470	QRZ0052-470	QRZ0052-470	QRD149J-470S
R161	Carbon Resistor	-	-	QRD141J-103S	-	-
R162	Carbon Resistor	-	-	QRD141J-823S	-	-
R163	Carbon Resistor	-	-	QRD141J-392S	-	-
R164	Carbon Resistor	-	-	QRD141J-222S	-	-
R165	Carbon Resistor	-	-	QRD141J-102S	-	-
R166	Carbon Resistor	-	-	QRD141J-224S	-	-
R170	UNF. Fuse Resistor \triangle	QRD149J-330S	QRZ0052-330	QRZ0052-330	QRZ0052-330	QRD149J-330S
R213	UNF. Fuse Resistor \triangle	QRD149J-470S	QRZ0052-470	QRZ0052-470	QRZ0052-470	-

\triangle : Safety Parts

9. Packing Materials and Part Numbers

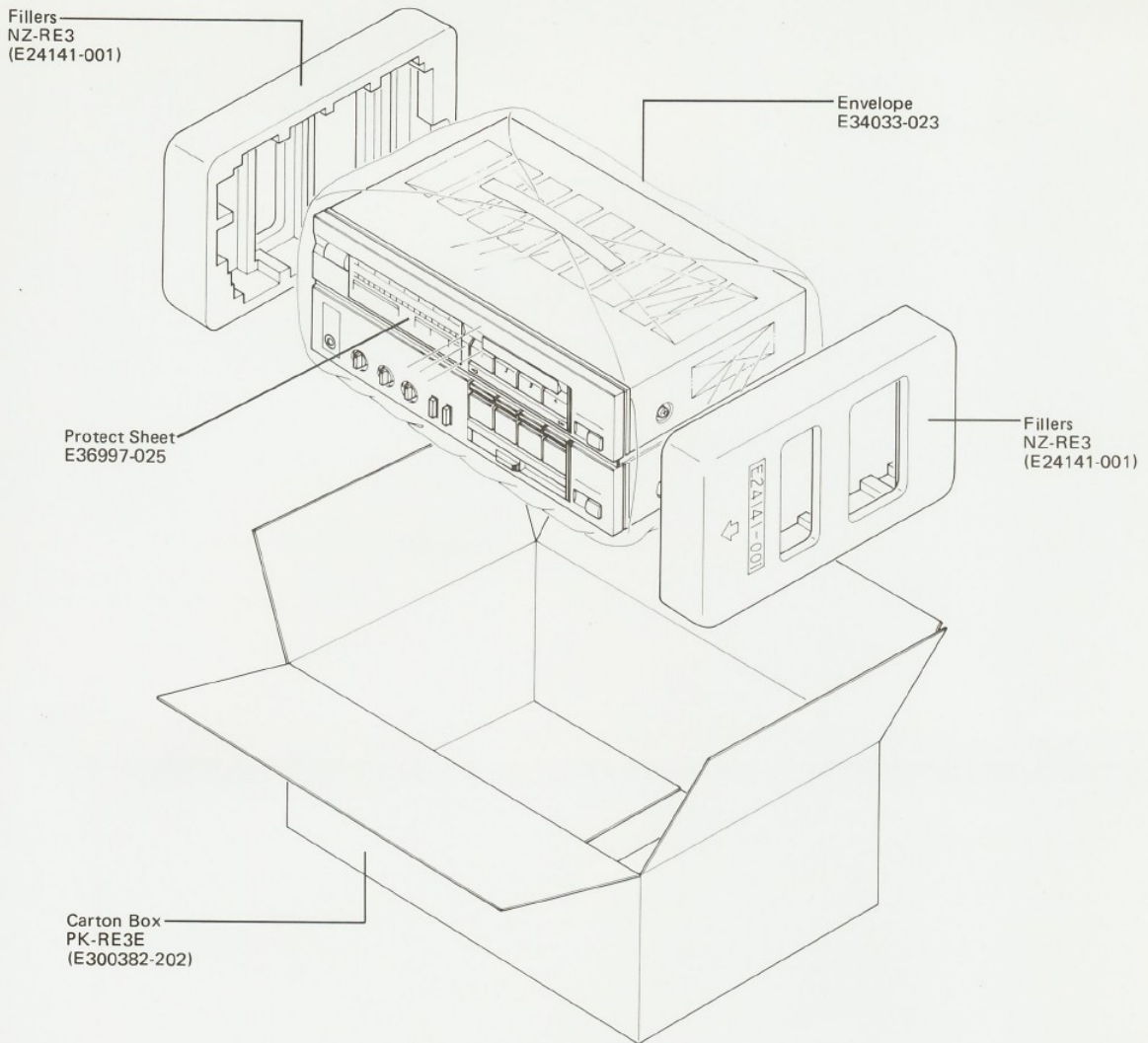

Fig. 10

10. Accessories List

Item No.	Part Number	Description	Q'ty
1	E30580-1004A	Instruction Book	1
2	See page 21	Warranty Card	1
3	E67007-001	Wire Antenna (for W. Germany only)	1
4	E03614-004	FM Antenna (Except W. Germany)	1
5	BT20044B	Service Procedures (for U.S.A. only)	1
6	BT20046	Service Information Card (for U.S.A. and U.S.Military Market)	1
7	BT20054-001A	FTZ Information (for W. Germany only)	1
8	E41202-2	Envelope for Instruction Book	1

11. Parts List with Specified Numbers for Designated Areas

Item No.	Description	U.S.A. & Canada	Europe & Australia	West Germany	U.K.	U.S. Military Market & Other Countries
1	Power Switch \triangle	QSP2206-001	QSP2206-002	QSP2206-002	QSP2206-002	QSP2206-002
2	Power Transformer \triangle	ETP1070-01JA (for U.S.A.) ETP1070-01CA (for Canada)	ETP1070-01EA	ETP1070-01EA	ETP1070-01EABS	ETP1070-01FA
3	Voltage Selector \triangle	—	—	—	—	QSR0085-001
4	Fuse Holder \triangle	—	—	—	—	QMG0301-003
5	Siemens Plug \triangle	—	—	—	—	E04056
6	AC Outlet \triangle	QMC0437-002	—	—	—	QMC0437-002
7	Power Cord \triangle	QMP1200-200	QMP3900-200 (for Europe) QMP2560-244 (for Australia)	QMP3900-200	QMP9017-008BS	QMP7600-250
8	Cord Stopper \triangle	QHS3876-162	QHS3876-162	QHS3876-162	QHS3876-162BS	QHS3876-162
9	Fuse Primary \triangle	QMF61U1-2R0 (2A)	QMF51A2-1R0L (1A)	QMF51A2-1R0L (1A)	QMF51A2-1R0LBS (1A)	QMF51A2-1R0L (1A, 220 V/240 V) QMF51A2-2R0L (2A, 110 V/120 V)
10	AC Cover \triangle	—	E302277-001 (for Europe only)	E302277-001	E302277-001	—
11	Tuner P.C. Board Ass'y	TFC-35B	TFC-35C	TFC-35D	TFC-35C	TFC-35E
12	Main Amp. P.C. Board Ass'y	TXX-399B (for U.S.A.) TXX-399C (for Canada)	TXX-399E	TXX-399G	TXX-399F	TXX-399D
13	Dial Scale	E302181-002	E302181-003	E302181-003	E302181-003	E302181-002
14	Rear Panel	E24139-002	E24139-004	E24139-005	E24139-004	E24139-003
15	9 kHz/10 kHz Select Switch	QSS2201-004	—	—	—	QSS2201-004
16	Switch Stopper	E67911-001	—	—	—	E67911-001
17	Antenna Terminal	E03572-016	E03572-016	EMB91YV-201A	E03572-016	E03572-016
18	Warranty Card	BT20048 (for U.S.A.) BT20025D (for Canada)	BT20029C (for Australia only)	—	BT20013C	BT20048 (for U.S. Military Market only)

\triangle : Safety Parts

POWER SPECIFICATIONS

Area	Line voltage & frequency	Power consumption
U.S.A. & CANADA	AC 120 V \sim , 60 Hz	120 watts 160 VA
CONTINENTAL EUROPE	AC 120 V \sim , 50 Hz	310 watts
U.K. & AUSTRALIA	AC 240 V \sim , 50 Hz	310 watts
OTHER AREAS	AC 110/120/220/240 V \sim Selectable, 50/60 Hz	310 watts

JVC

VICTOR COMPANY OF JAPAN, LIMITED, TOKYO, JAPAN

 Printed in Japan
2002-V

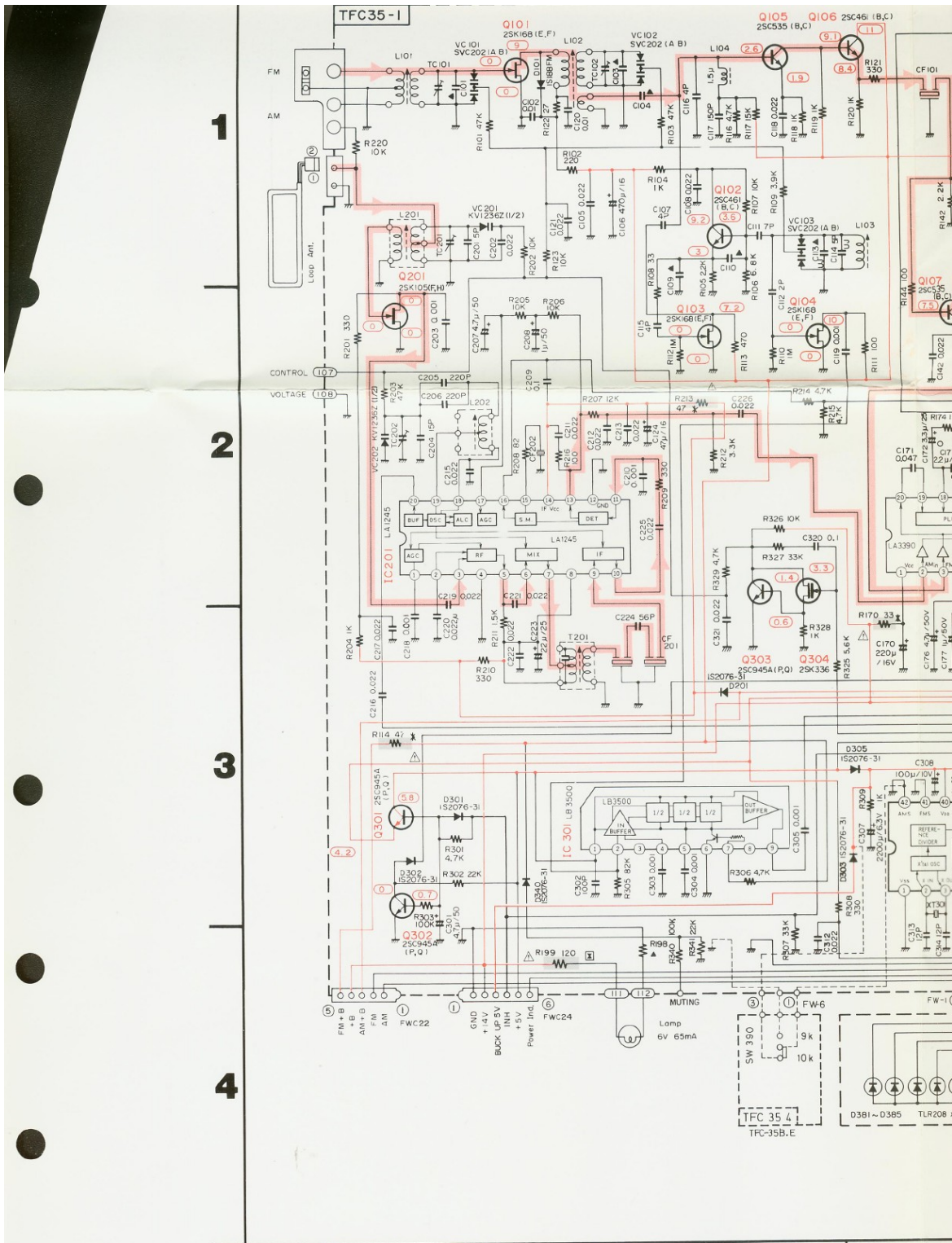

Printed Circuit Board Ass'y Locations

P.C. Board Ass'y	Description	Page
TXX-399	Main Amp. and Other Functions Split P.C. Board Ass'y	8
TFC-35	Tuner and Other Functions Split P.C. Board Ass'y	12

Notes:

1. shows DC volt
2. Voltage values in indicates posit
3. indicates signa
4. indicates signa
5. When replacing the those marked with those to ensure safety.

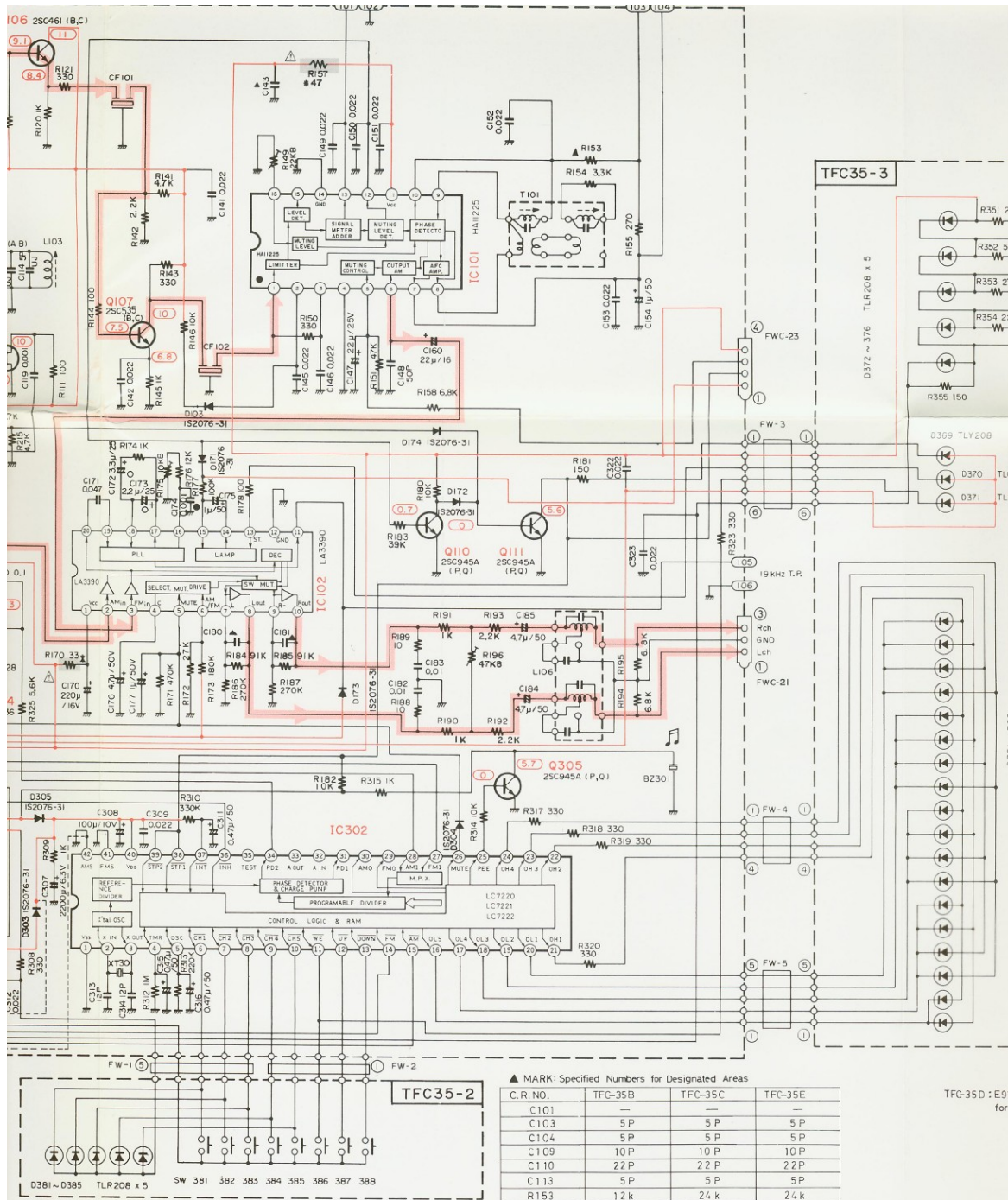

▲ MARK: Specified Numbers for Designated Areas

C. R. NO.	TFC-35B	TFC-35C	TFC-35E
C101	—	—	—
C103	5 P	5 P	5 P
C104	5 P	5 P	5 P
C109	10 P	10 P	10 P
C110	22 P	22 P	22 P
C113	5 P	5 P	5 P
R153	12 k	24 k	24 k
C180, 181	820 P	560 P	820 P
IC 302	LC 7220	LC 7222	LC 7222
C143	0.022	—	—
R198	10Ω	—	10Ω
Area	USA & Canada	U.K. & Europe	US Military Market & Other Countries

TFC-35D : E91 for 1

C

D

E

Notes:
 ○ shows DC voltage to the chassis with no signal input.
 Voltage values in □ are positive.
 □ indicates positive B power supply.
 □ indicates signal path.
 When replacing the parts in the darkened area (■) and those marked with ▲, be sure to use the designated parts to ensure safety.

6. Parts in red indicate transistors or ICs.
 7. This is the standard circuit diagram.
 The design and contents are subject to change without notice.

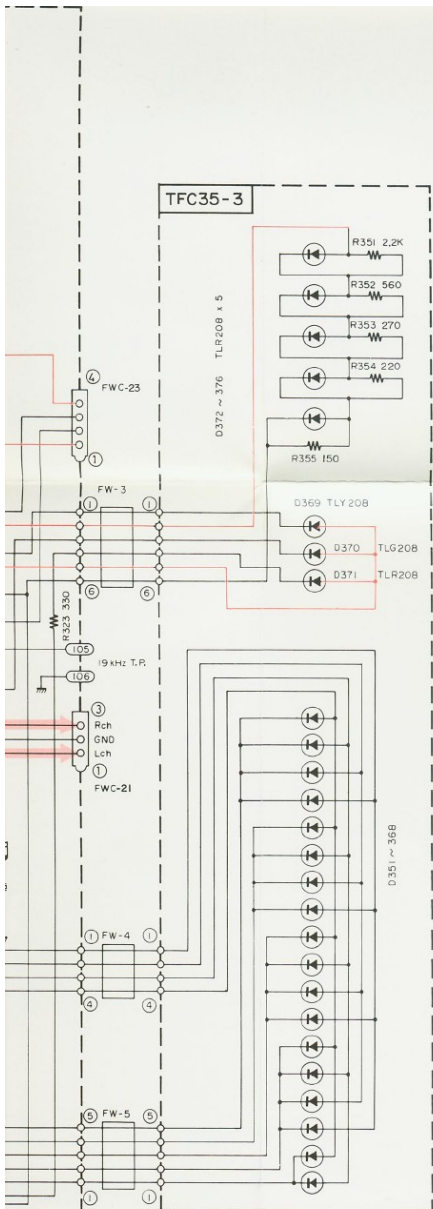

	IC101	IC102	IC201	IC301	IC302
1	1.9	13.3	5.8	5.8	0
2	1.9	4.5	2.3	3.5	1.3
3	1.9	4.5	2.8	0	2.4
4	0	0.3	0	3.5	5.0
5	0	0	9.8	0	5.0
6	5.6	0.5	2.2	0	0.2
7	5.8	4.5	10.3	4.2	5.0
8	5.8	5.6	10.3	0	5.0
9	5.8	4.5	2.8	4.0	5.0
10	5.8	5.6	9.2		5.0
11	13.6	3.2	0.7		5.0
12	1.0	0	0		5.0
13	0.5	2.7	1.7		5.0
14	0	2.5	13.2		0
15	5.0	2.5	1.7		5.0
16	4.0	2.4	0.0		0.7
17		2.5	2.0		0.7
18		2.5	5.6		0.7
19		2.5	5.6		0.7
20		4.2	3.0		0.1
21					4.7
22					0
23					0
24					0
25					0.1
26					0.1
27					2.0
28					0.05
29					0.3
30					0.1
31					0.3
32					0.2
33					0
34					1.7
35					0
36					5.2
37					4.8
38					5.5
39					5.5
40					5.0
41					0
42					0

NOTE

- x 1/4W UNFLAMMABLE RESISTOR
- 1 W UNFLAMMABLE RESISTOR
- △ 50W MYLAR CAPACITOR
- POLYPROPYLENE CAPACITOR
- LLC ELECTROLYTIC CAPACITOR
- NON MARK 1/4W CARBON RESISTOR
- NON MARK -||- CERAMIC CAPACITOR
- ||- ELECTROLYTIC CAPACITOR

VOLTAGES ARE MEASURED WITH DC V.T.V.M. AT FM POSITION
 NDN SIGNAL
 IC201 : AM POSITION

Designated Areas

TFC-35C	TFC-35E
—	—
5 P	5 P
5 P	5 P
10 P	10 P
22 P	22 P
5 P	5 P
24 k	24 k
560 P	820 P
LC 7222	LC 7222
—	—
—	10Ω
U.K. & Europe	US Military Market & Other Countries

TFC-35D : E91278 SHEET 2/2 (Next page)
 for W.Germany only

ICs.
 subject to change without

8. R-E3 Schematic Diagram

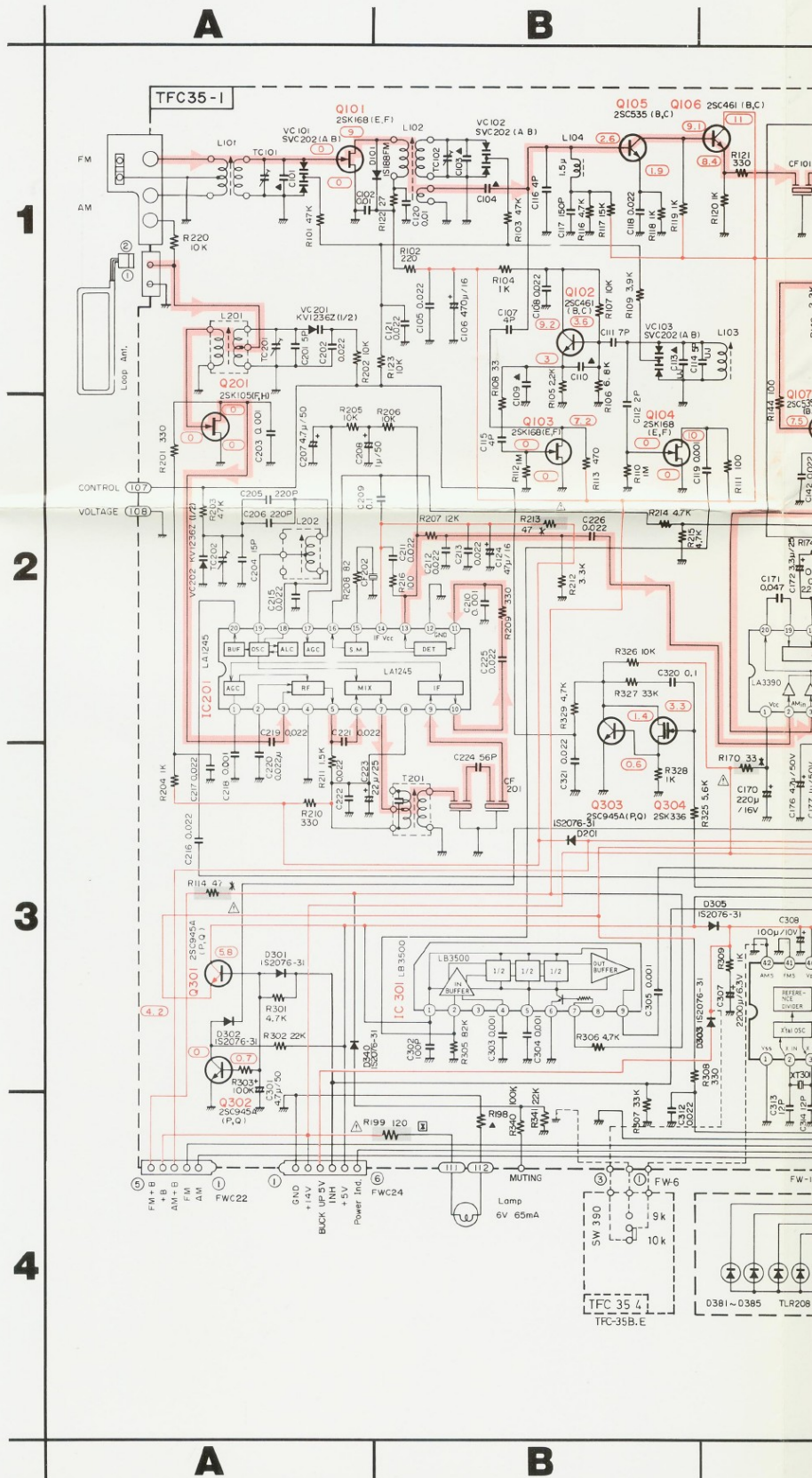

Printed Circuit Board Ass'y Locations

P.C. Board Ass'y	Description	Page
TXX-399	Main Amp. and Other Functions Split P.C. Board Ass'y	8

- Notes:
1. shows DC level
 2. Voltage values in indicate
 3. indicates posit
 4. indicates signa
 5. When replacin

E

F

R T.P.

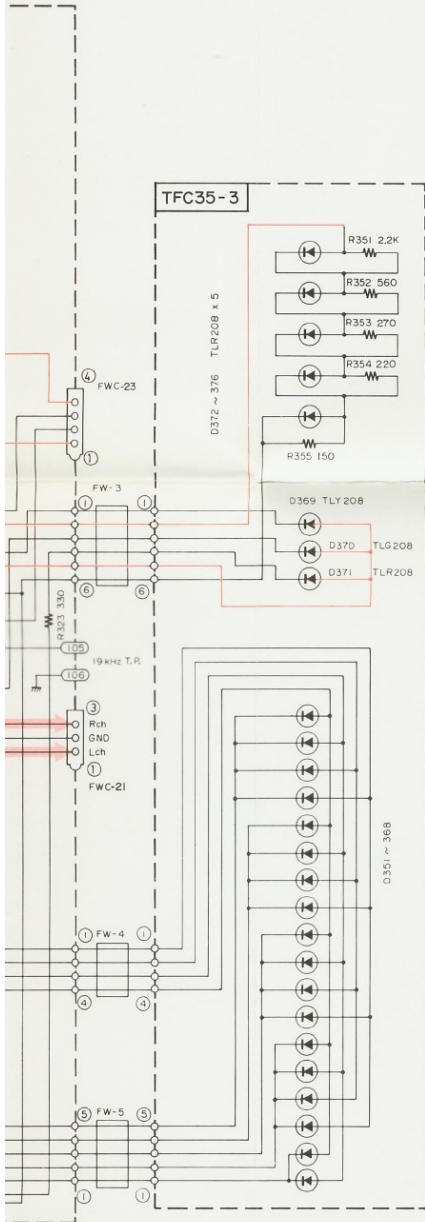

	IC101	IC102	IC201	IC301	IC302
1	1.9	13.3	5.8	5.8	0
2	1.9	4.5	2.3	3.5	1.3
3	1.9	4.5	2.8	0	2.4
4	0	0.3	0	3.5	5.0
5	0	0	9.8	0	5.0
6	5.6	0.5	2.2	0	0.2
7	5.8	4.5	10.3	4.2	5.0
8	5.8	5.6	10.3	0	5.0
9	5.8	4.5	2.8	4.0	5.0
10	5.8	5.6	9.2		5.0
11	13.6	3.2	0.7		5.0
12	1.0	0	0		5.0
13	0.5	2.7	1.7		5.0
14	0	2.5	13.2		0
15	5.0	2.5	1.7		5.0
16	4.0	2.4	0.0		0.7
17		2.5	2.0		0.7
18		2.5	5.6		0.7
19		2.5	5.6		0.7
20		4.2	3.0		0.1
21					4.7
22					0
23					0
24					0
25					0.1
26					0.1
27					2.0
28					0.05
29					0.3
30					0.1
31					0.3
32					0.2
33					0
34					1.7
35					0
36					5.2
37					4.8
38					5.5
39					5.5
40					5.0
41					0
42					0

NOTE

- * 1/4W UNFLAMMABLE RESISTOR
- 1W UNFLAMMABLE RESISTOR
- △ 50V MYLAR CAPACITOR
- POLYPROPYLENE CAPACITOR
- LLC ELECTROLYTIC CAPACITOR
- NON MARK 1/4W CARBON RESISTOR
- NON MARK CERAMIC CAPACITOR
- ELECTROLYTIC CAPACITOR

VOLTAGES ARE MEASURED WITH DC V.T.V.M. AT FM POSITION
NON SIGNAL
IC201 : AM POSITION

Designated Areas

TFC-35C	TFC-35E
—	—
5 P	5 P
5 P	5 P
10 P	10 P
22 P	22 P
5 P	5 P
24 k	24 k
560 P	820 P
LC7222	LC7222
—	—
—	10 Ω
UK & Europe	US Military Market & Other Countries

TFC-35D : E91278 SHEET 2/2 (Next page)
for W.Germany only

1

2

3

4

E

F

Os.

ect to change without

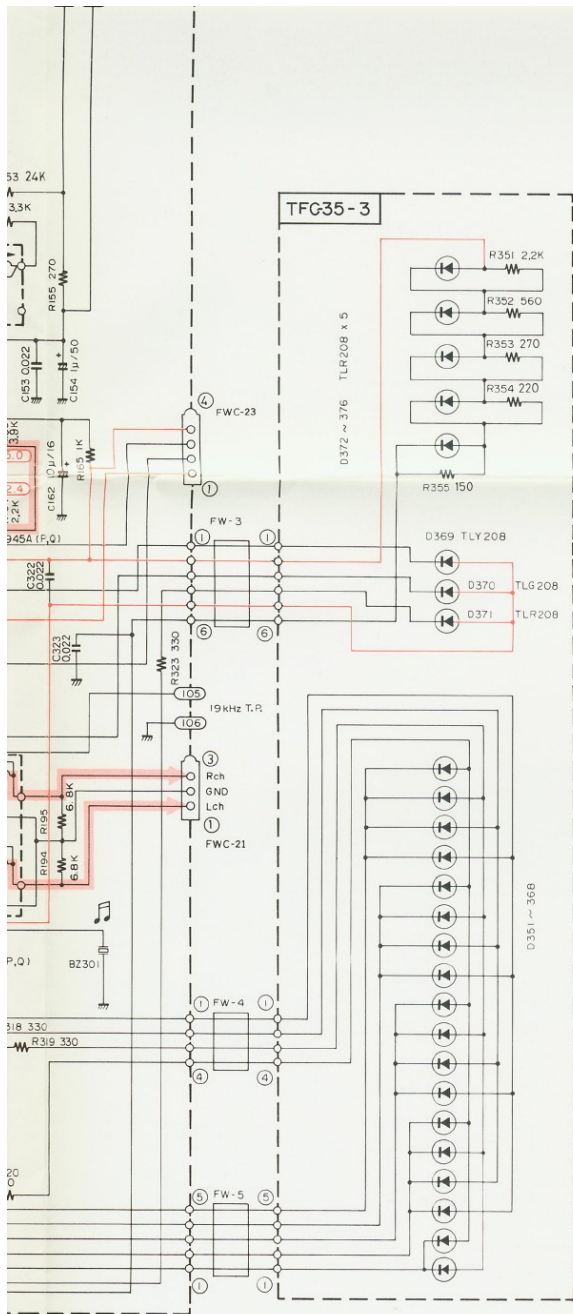

	IC101	IC102	IC201	IC301	IC302
1	1.9	13.3	5.8	5.8	0
2	1.9	4.5	2.3	3.5	1.3
3	1.9	4.5	2.8	0	2.4
4	0	0.3	0	3.5	5.0
5	0	0	9.8	0	5.0
6	5.6	0.5	2.2	0	0.2
7	5.8	4.5	10.3	4.2	5.0
8	5.8	5.6	10.3	0	5.0
9	5.8	4.5	2.8	4.0	5.0
10	5.8	5.6	9.2		5.0
11	13.6	3.2	0.7		5.0
12	1.0	0	0		5.0
13	0.5	2.7	1.7		5.0
14	0	2.5	13.2		0
15	5.0	2.5	1.7		5.0
16	4.0	2.4	0.0		0.7
17		2.5	2.0		0.7
18		2.5	5.6		0.7
19		2.5	5.6		0.7
20		4.2	3.0		0.1
21					4.7
22					0
23					0
24					0
25					0.1
26					0.1
27					2.0
28					0.05
29					0.3
30					0.1
31					0.3
32					0.2
33					0
34					1.7
35					0
36					5.2
37					4.8
38					5.5
39					5.5
40					5.0
41					0
42					0

NOTE

- * 1/4W UNFLAMMABLE RESISTOR
- 1W UNFLAMMABLE RESISTOR
- △ 5W NYLON CAPACITOR
- POLYPROPYLENE CAPACITOR
- LLG ELECTROLYTIC CAPACITOR
- NON MARK 1/4W CARBON RESISTOR
- NON MARK — CERAMIC CAPACITOR
- ELECTROLYTIC CAPACITOR

VOLTAGES ARE MEASURED WITH
 DC V.T.V.M. AT FM POSITION
 NON SIGNAL
 IC201 : AM POSITION

Germany only

...
 ...ect to change without

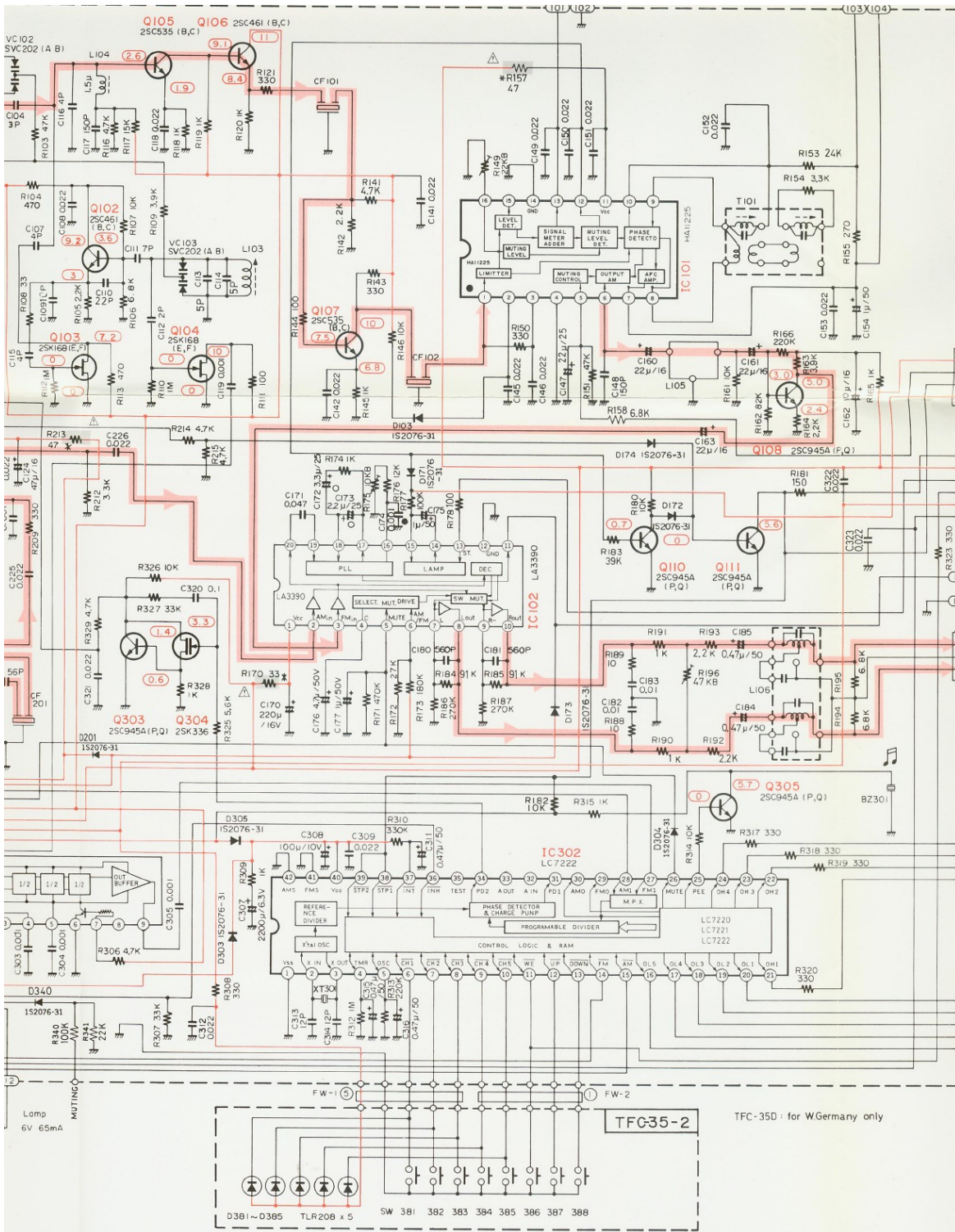

B

C

D

Notes:

1. shows DC voltage to the chassis with no signal input.
2. Voltage values in are positive.
3. indicates positive B power supply.
4. indicates signal path.
5. When replacing the parts in the darkened area () and those marked with Δ , be sure to use the designated parts to ensure safety.
6. Parts in red indicate transistors or ICs.
7. This is the standard circuit diagram. The design and contents are subject to change without notice.

Page	8
sy	12

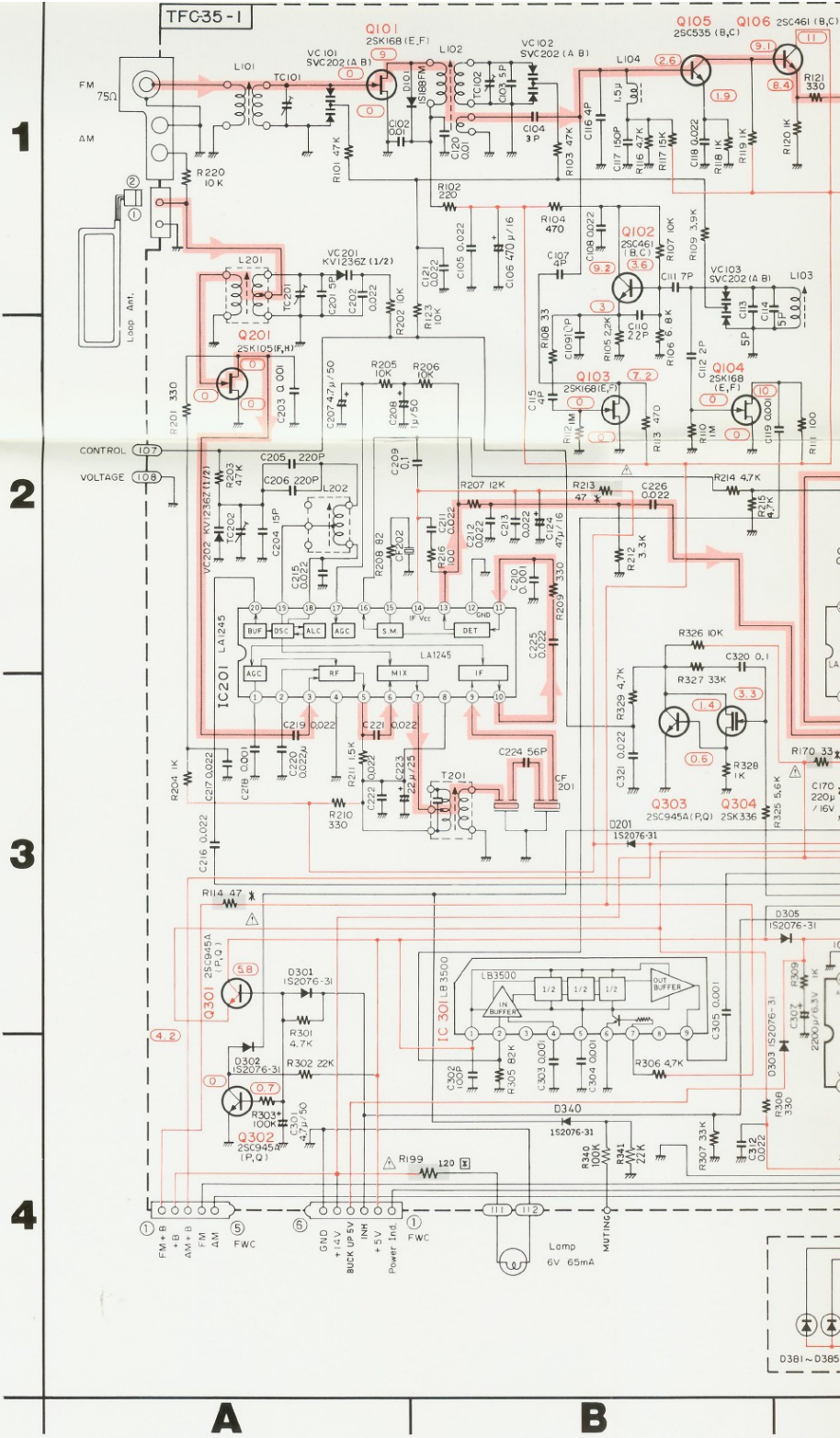

Printed Circuit Board Ass'y Locations

P.C. Board Ass'y	Description	Page
TXX-399	Main Amp. and Other Functions Split P.C. Board Ass'y	8
TFC-35	Tuner and Other Functions Split P.C. Board Ass'y	12

- Notes:
1. shows DC vol
 2. Voltage values in indicates posi
 3. indicates posi
 4. indicates sign
 5. When replacing the those marked with those to ensure safety.

E

F

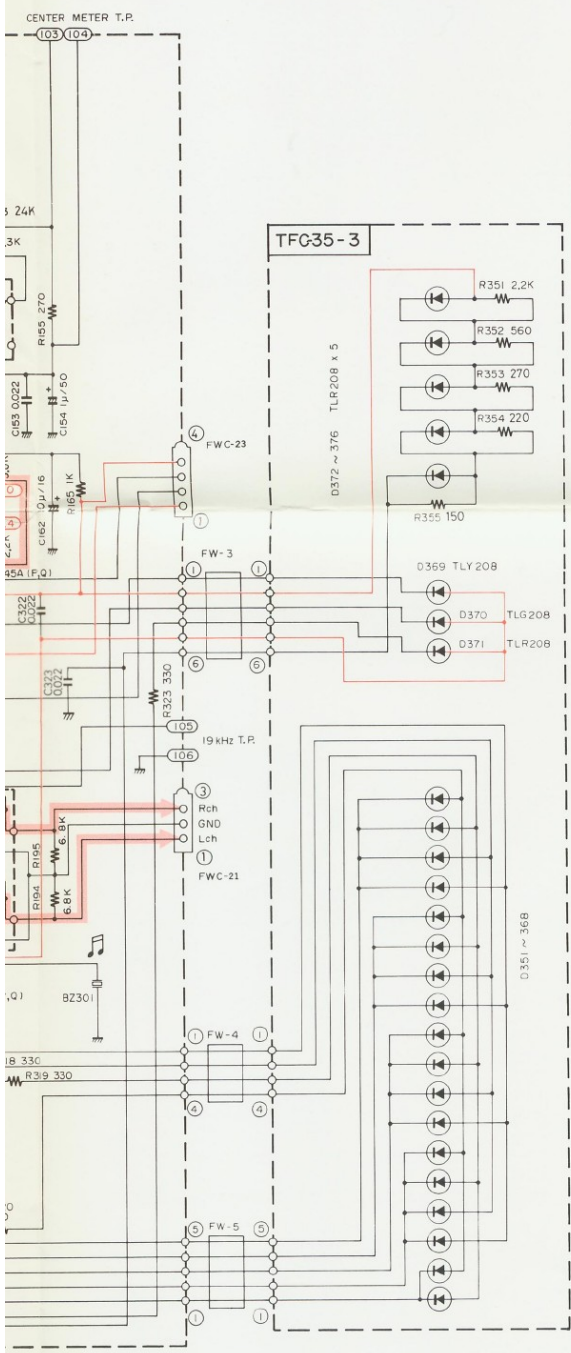

	IC 101	IC 102	IC 201	IC 301	IC 302
1	1.9	13.3	5.8	5.8	0
2	1.9	4.5	2.3	3.5	1.3
3	1.9	4.5	2.8	0	2.4
4	0	0.3	0	3.5	5.0
5	0	0	9.8	0	5.0
6	5.6	0.5	2.2	0	0.2
7	5.8	4.5	10.3	4.2	5.0
8	5.8	5.6	10.3	0	5.0
9	5.8	4.5	2.8	4.0	5.0
10	5.8	5.6	9.2		5.0
11	13.6	3.2	0.7		5.0
12	1.0	0	0		5.0
13	0.5	2.7	1.7		5.0
14	0	2.5	13.2		0
15	5.0	2.5	1.7		5.0
16	4.0	2.4	0.0		0.7
17		2.5	2.0		0.7
18		2.5	5.6		0.7
19		2.5	5.6		0.7
20		4.2	3.0		0.1
21					4.7
22					0
23					0
24					0
25					0.1
26					0.1
27					2.0
28					0.05
29					0.3
30					0.1
31					0.3
32					0.2
33					0
34					1.7
35					0
36					5.2
37					4.8
38					5.5
39					5.5
40					5.0
41					0
42					0

1

2

3

4

NOTE

- * 1/4W UNFLAMMABLE RESISTOR
- 1W UNFLAMMABLE RESISTOR
- △ 50W MYLAR CAPACITOR
- POLYPROPYLENE CAPACITOR
- LLC ELECTROLYTIC CAPACITOR
- NON-MARK 1/4W CARBON RESISTOR
- NON-MARK CERAMIC CAPACITOR
- ⊥ ELECTROLYTIC CAPACITOR

VOLTAGES ARE MEASURED WITH DC V.T.V.M. AT FM POSITION, NON SIGNAL, IC201 - AM POSITION

V.Germany only

E

F

2s.
ect to change without

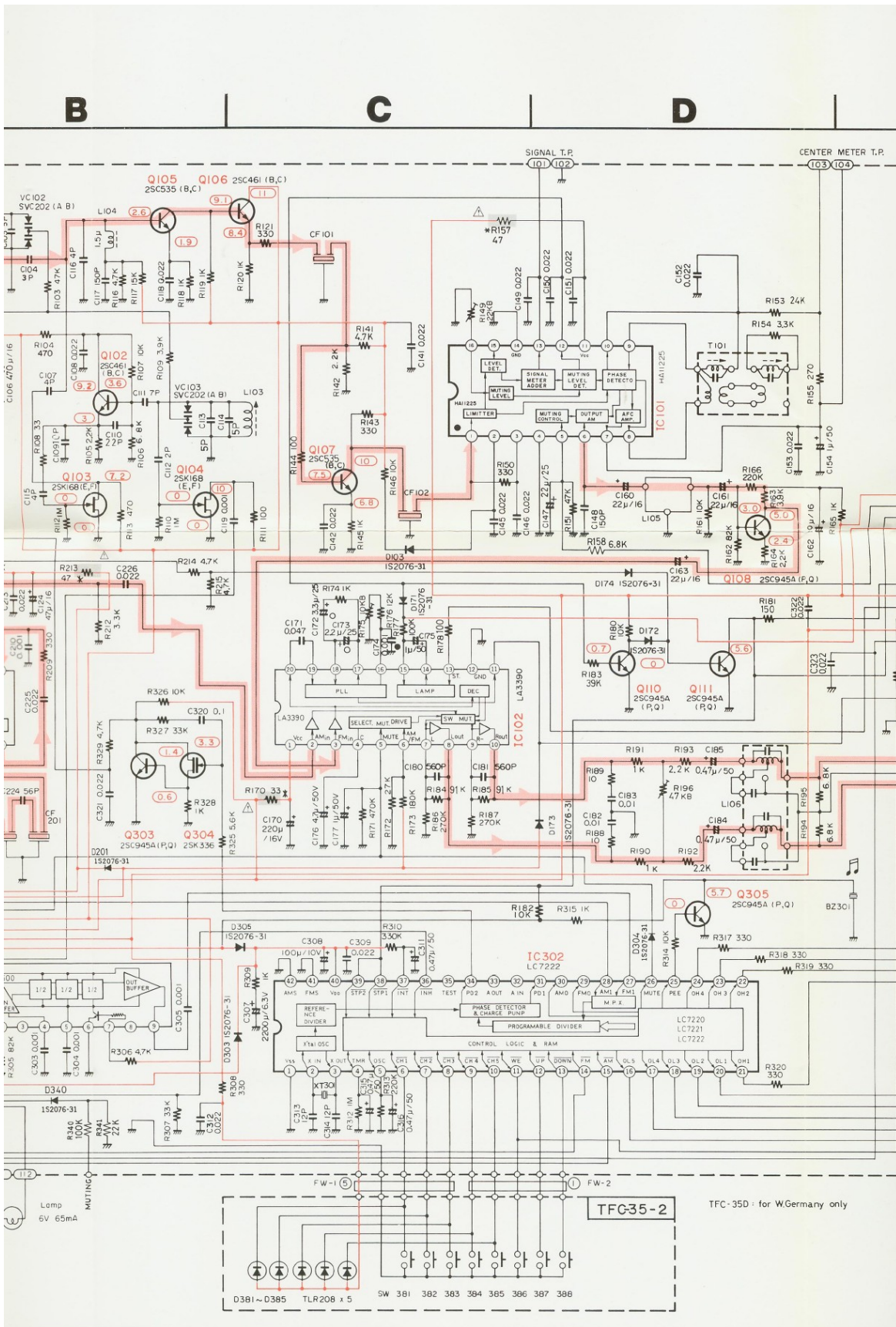

Notes:

1. shows DC voltage to the chassis with no signal input.
2. Voltage values in are positive.
3. indicates positive B power supply.
4. indicates signal path.
5. When replacing the parts in the darkened area () and

6. Parts in red indicate transistors or ICs.
7. This is the standard circuit diagram.

The design and contents are subject to change without notice.

Page	
8	
12	

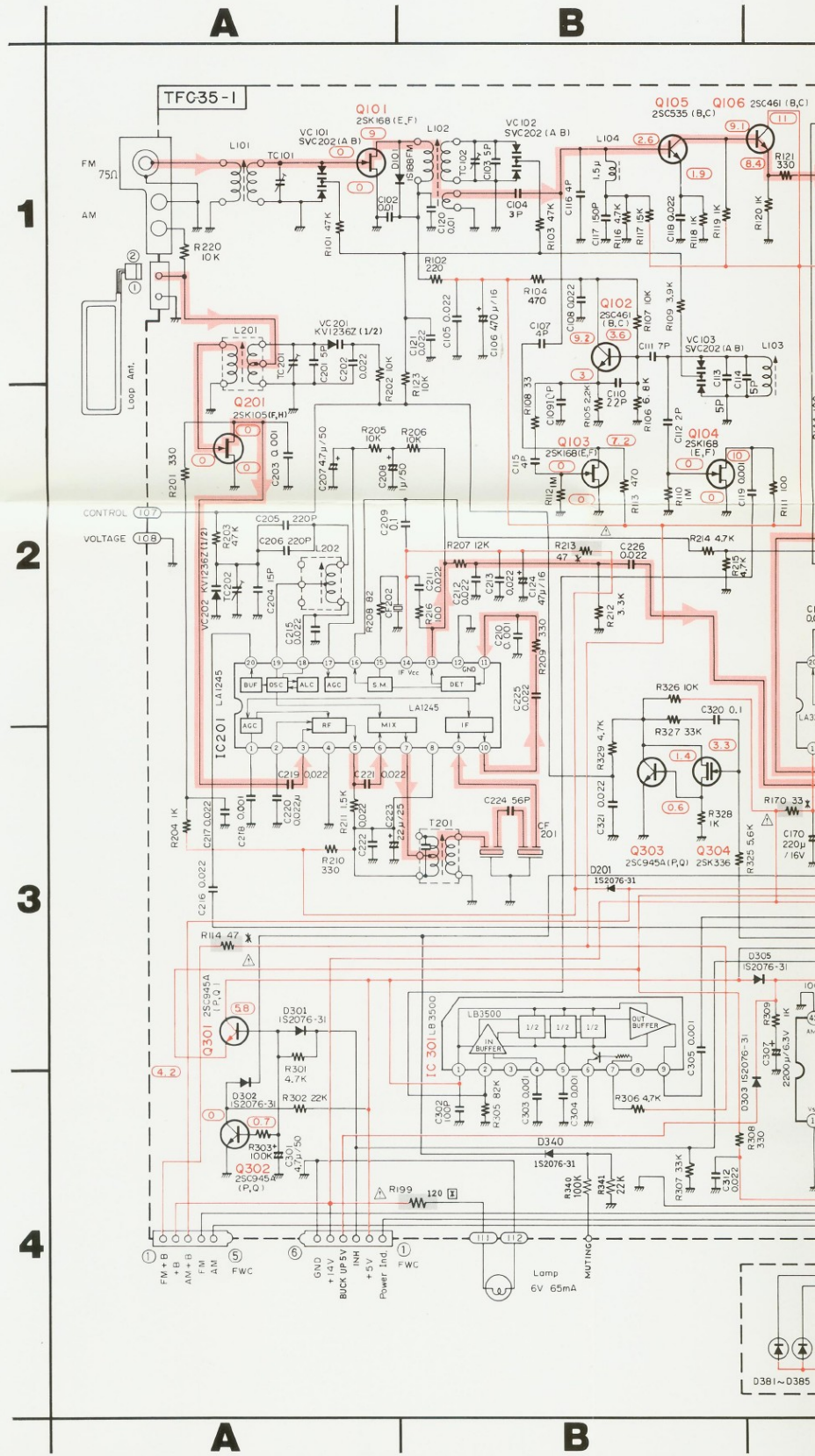

Printed Circuit Board Ass'y Locations

P.C. Board Ass'y	Description	Page
TXX-399	Main Amp. and Other Functions Split P.C. Board Ass'y	8
TFC-35	Tuner and Other Functions Split P.C. Board Ass'y	12

Notes:

1. shows DC vol
2. Voltage values in
3. indicates posit
4. indicates signa
5. When replacing the

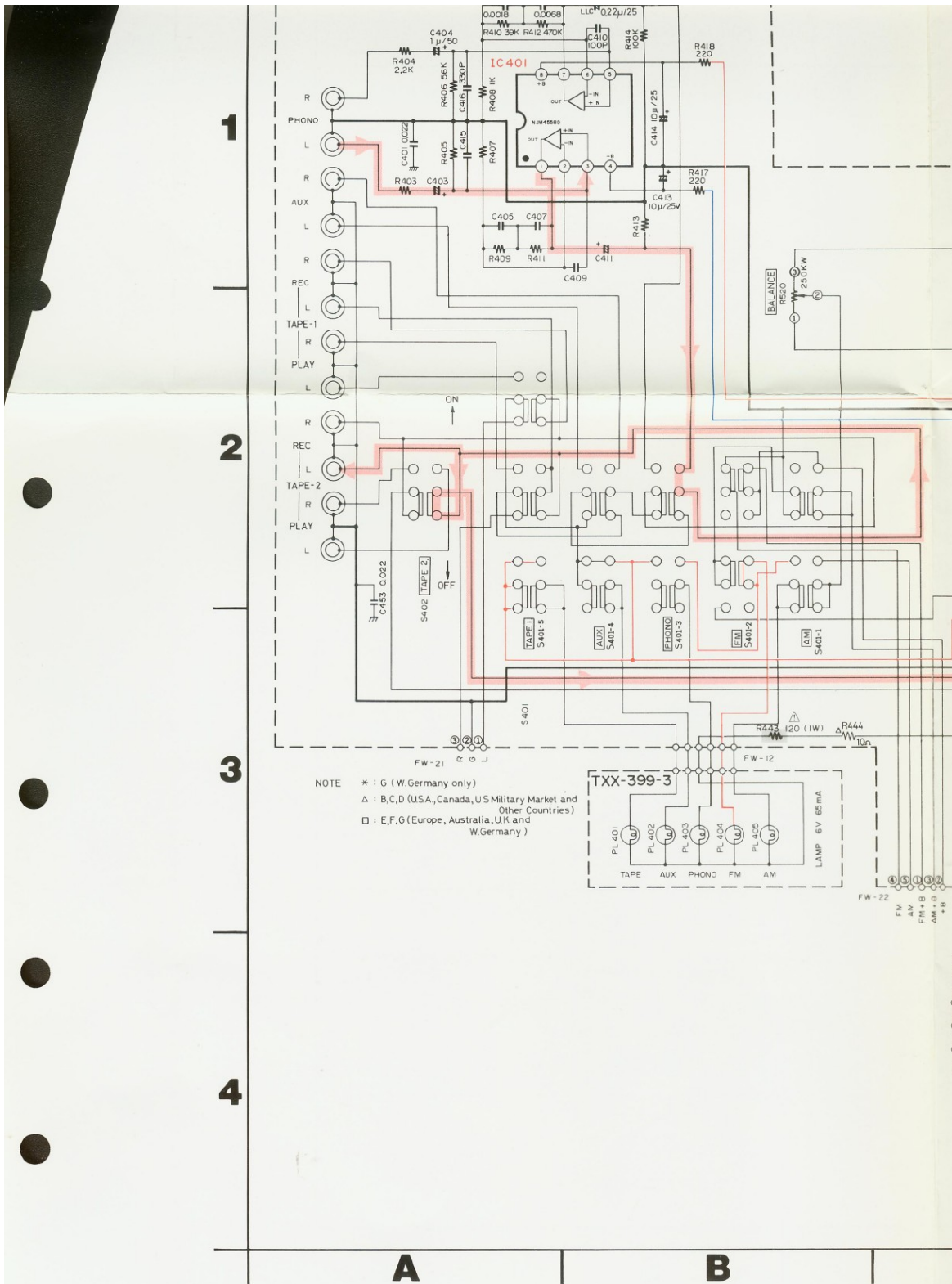

Printed Circuit Board Ass'y Locations

P.C. Board Ass'y	Description	Page
TXX-399	Main Amp. and Other Functions Split P.C. Board Ass'y	8
TFC-35	Tuner and Other Functions Split P.C. Board Ass'y	12

Notes:

1. shows DC volt
2. Voltage values in □
3. Voltage values in □
4. indicates posit
5. indicates nega
6. indicates signa
7. When replacing the those marked with to ensure safety.

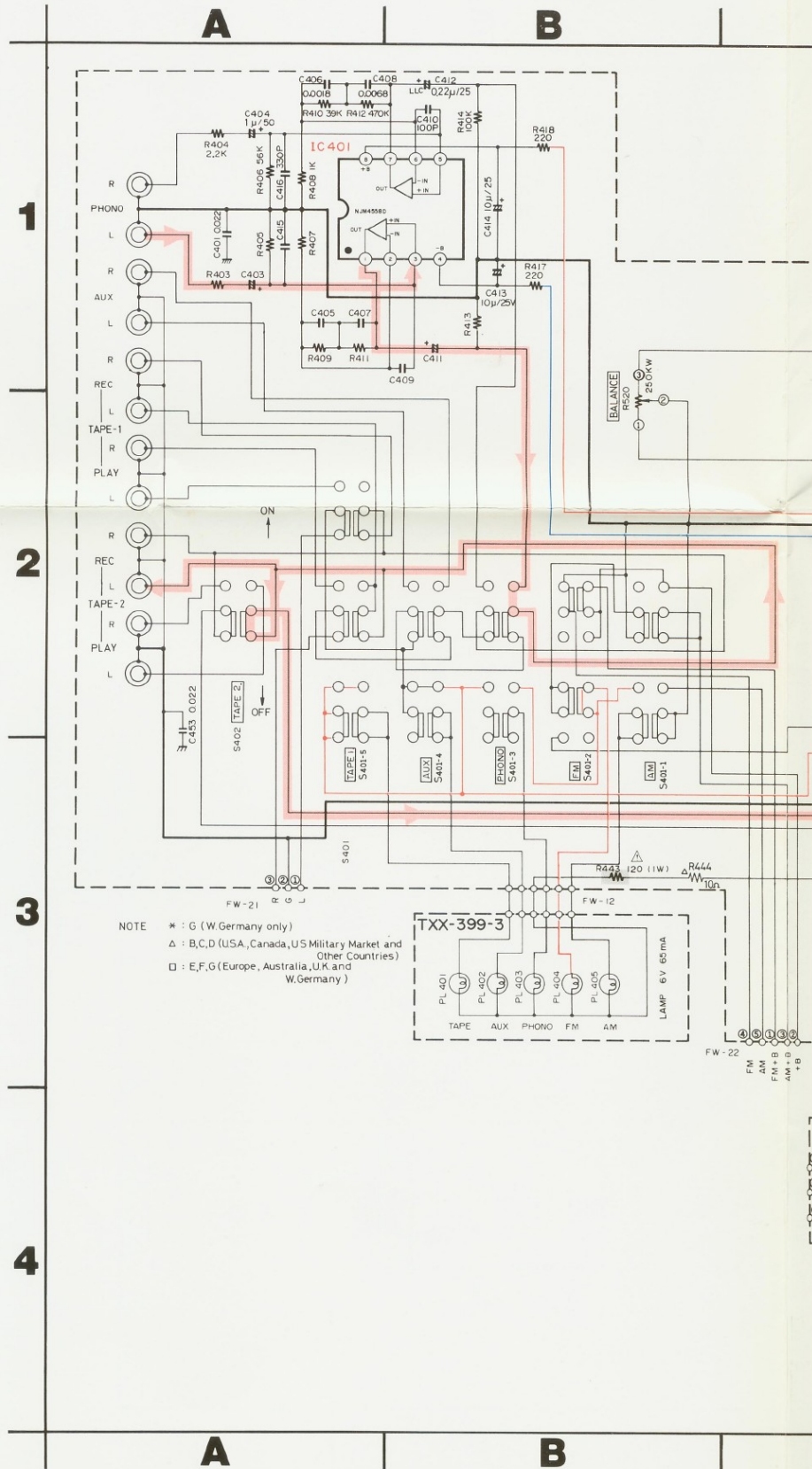

Printed Circuit Board Ass'y Locations

P.C. Board Ass'y	Description	Page
TXX-399	Main Amp. and Other Functions Split P.C. Board Ass'y	8
TFC-35	Tuner and Other Functions Split P.C. Board Ass'y	12

Notes:

1. shows DC volt
2. Voltage values in
3. Voltage values in
4. indicates positive
5. indicates negative

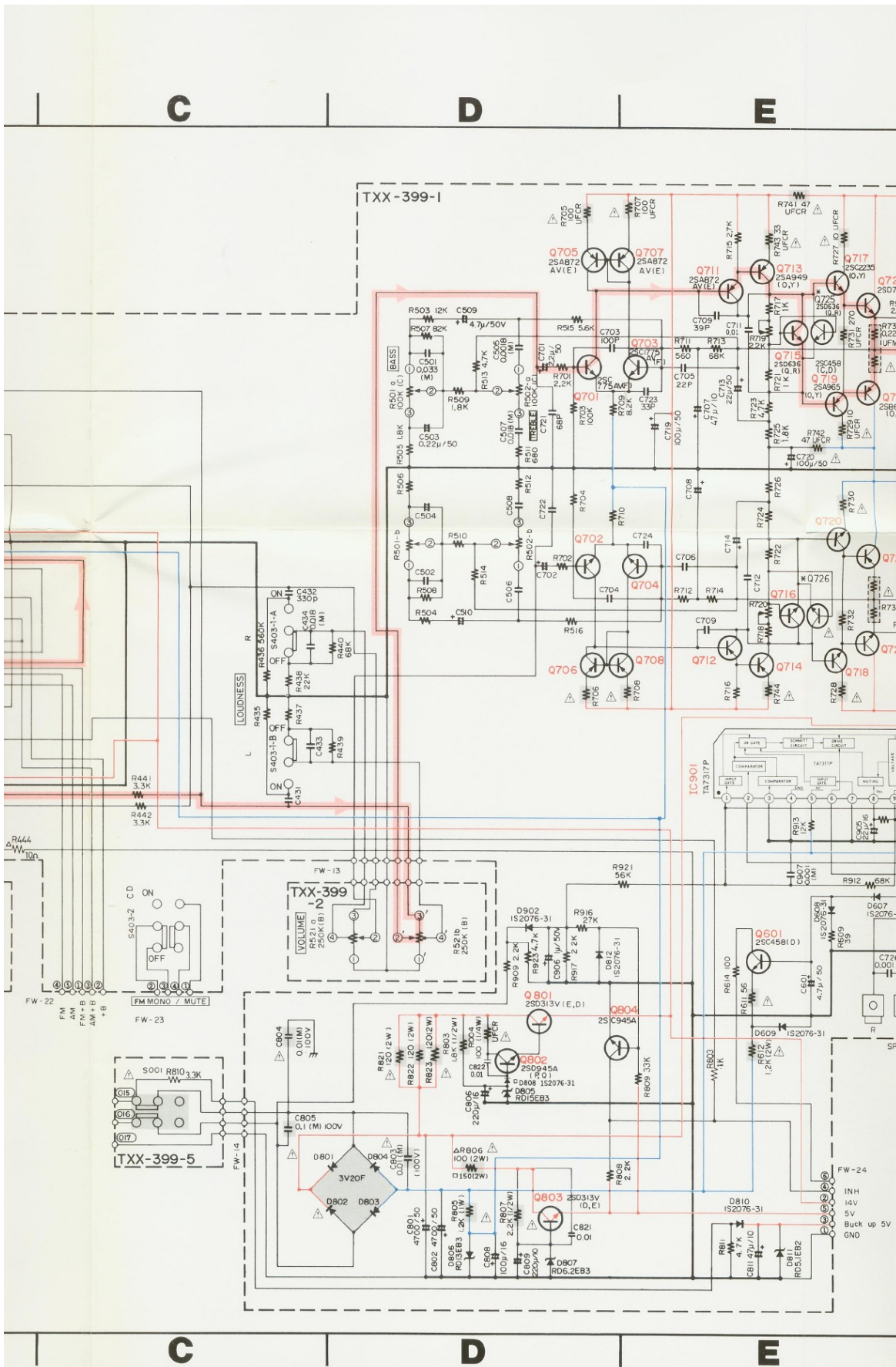

- es:
- shows DC voltage to the chassis with no signal input.
 - Voltage values in are positive.
 - Voltage values in are negative.
 - indicates positive B power supply.
 - indicates negative B power supply.
8. Parts in red indicate transistors or ICs.
 9. This is the standard circuit diagram.
- The design and contents are subject to change without notice.

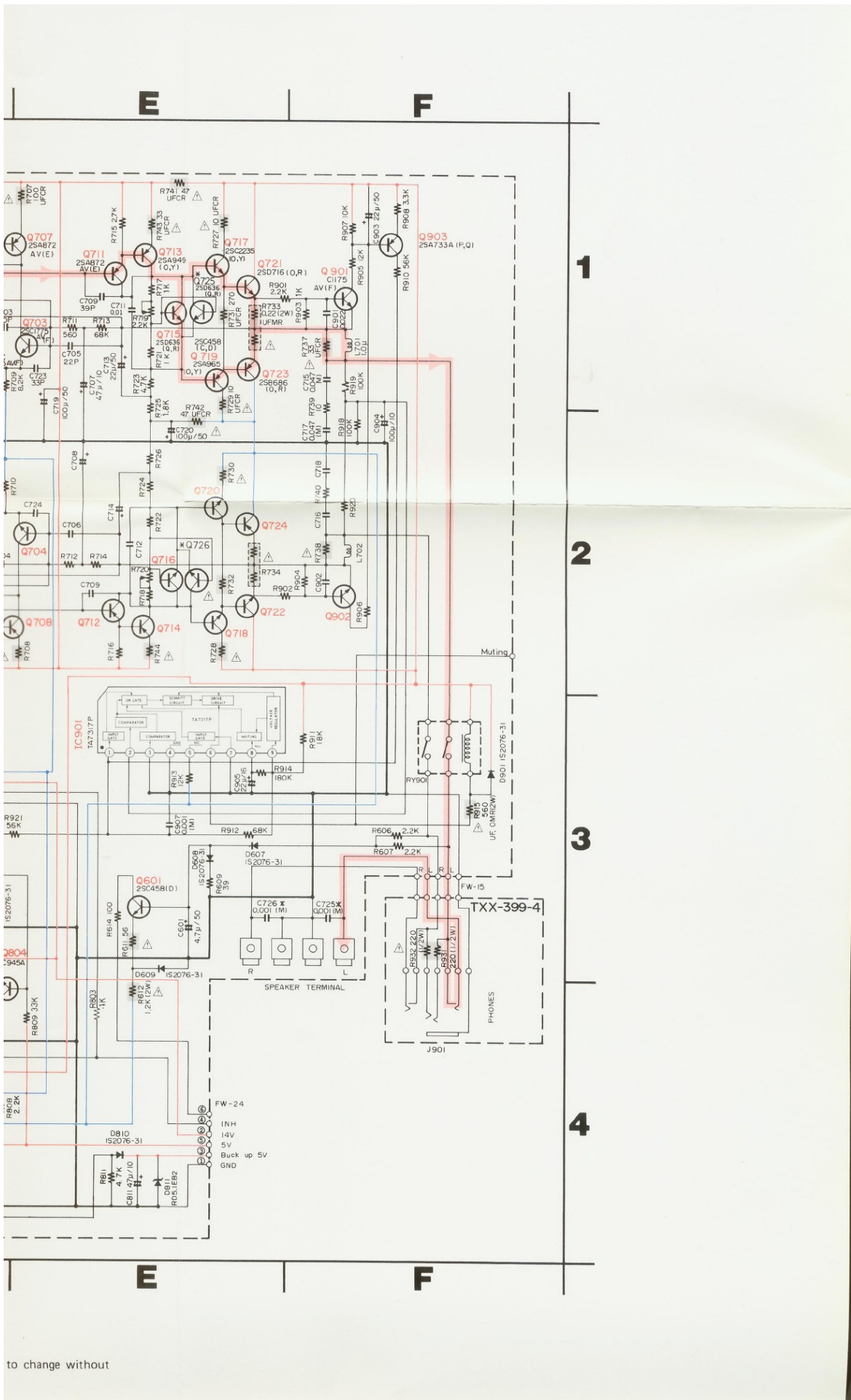

to change without

D

E

F

(C) FOR CANADA AC120V 60Hz

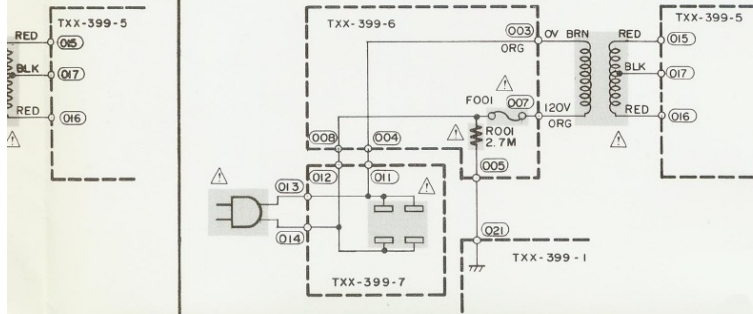

1

(E,G) FOR EUROPE AC 220V 50Hz

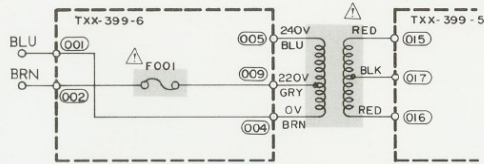

2

(A, BS) (A) FOR AUSTRALIA
(BS) FOR U.K. 240V 50Hz

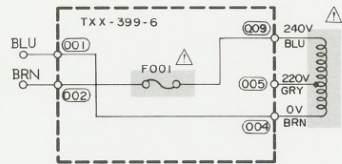

3

4

D

E

F

A

B

C

D

(D) 国内

(J) FOR U.S.A. AC120V 60Hz

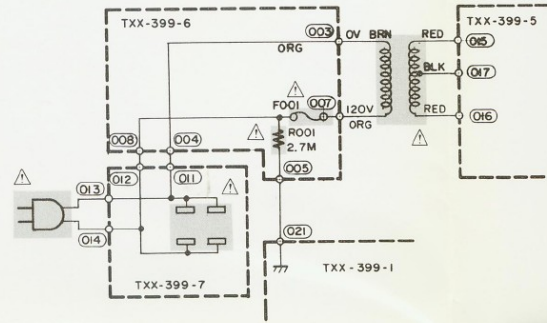
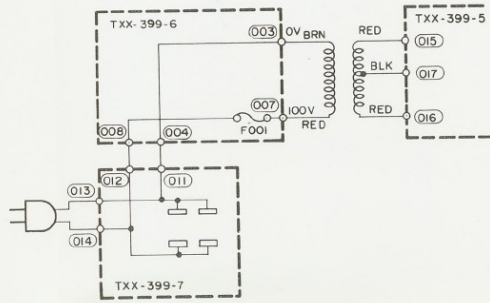

(U,P) (U) FOR OTHER COUNTRIES
(P) FOR U.S.Military Market

(E,G)

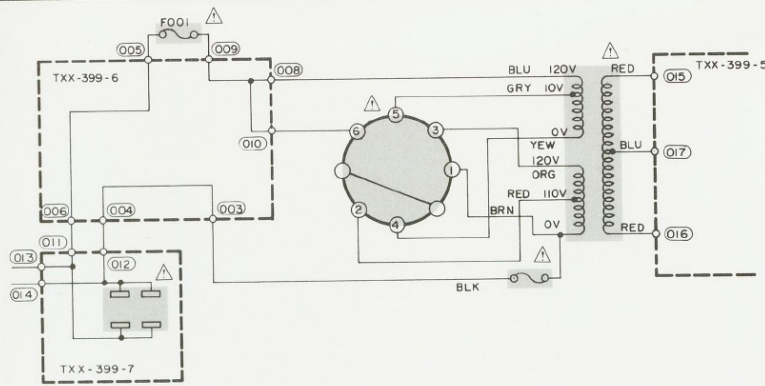

VOLTAGE SELECTOR CONNECTION

(A, BS)

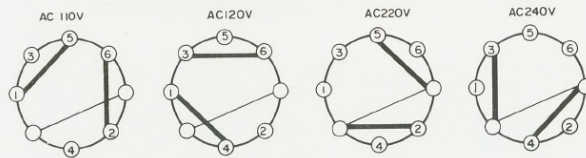

A

B

C

D

A

(D) 国内

1

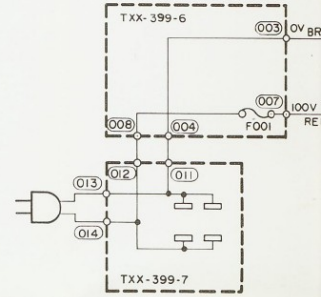

(U,P) (U) FOR OTHER CC (P) FOR U.S.Military

2

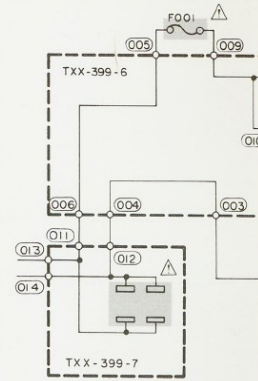

3

VOLTAGE SELEC

4

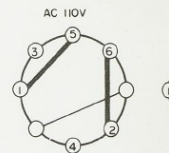

A