

200 SERIES TWO POWER AMPLIFIER

Service Manual

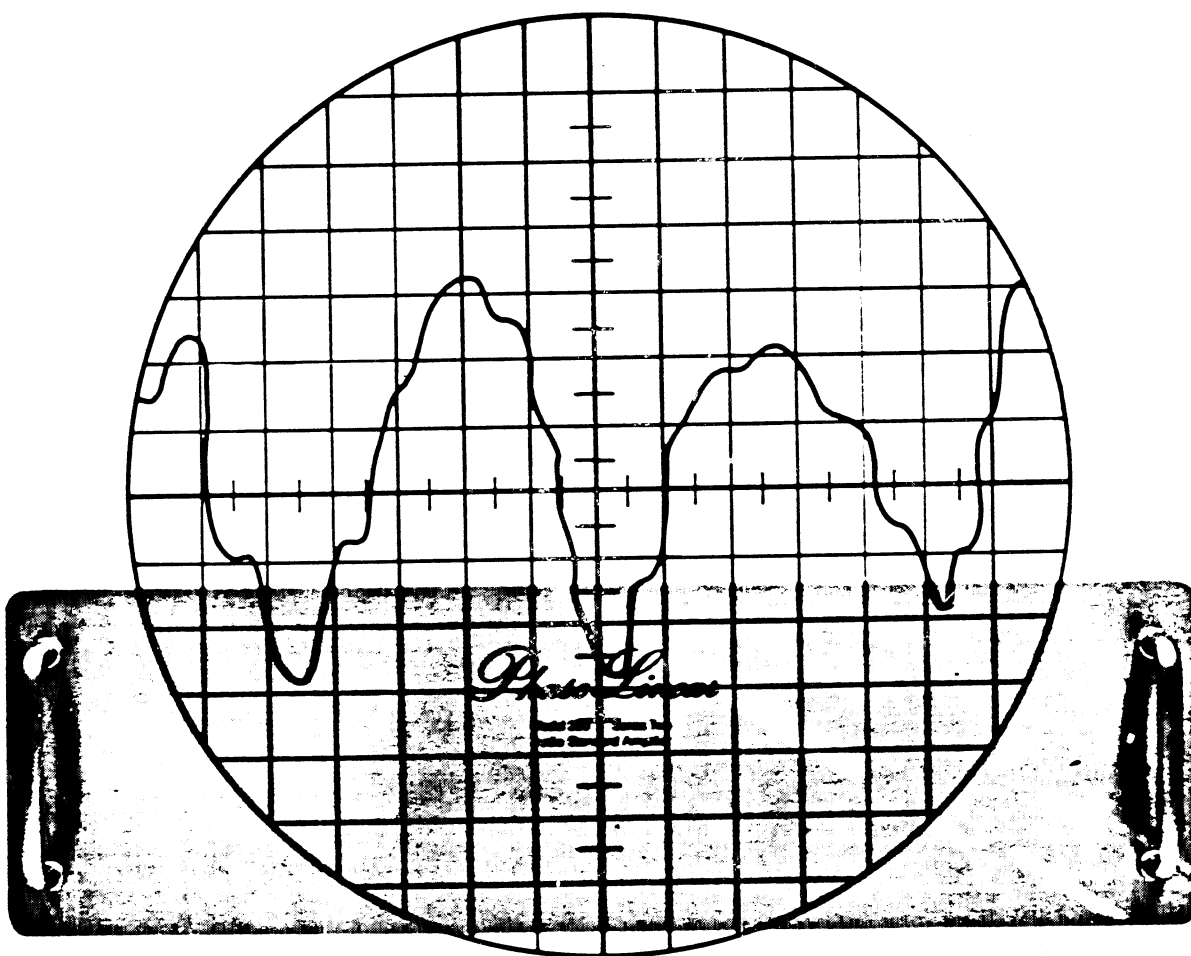

Phase Linear
CORPORATION

THIS DOCUMENT
PROVIDED BY
WATTS_ABUNDANT.

CONTACT US AT

watts.abundant@yahoo.com

FOR PARTS AND
SERVICE

POWER TRANSFORMER PRIMARY WIRING DIAGRAM

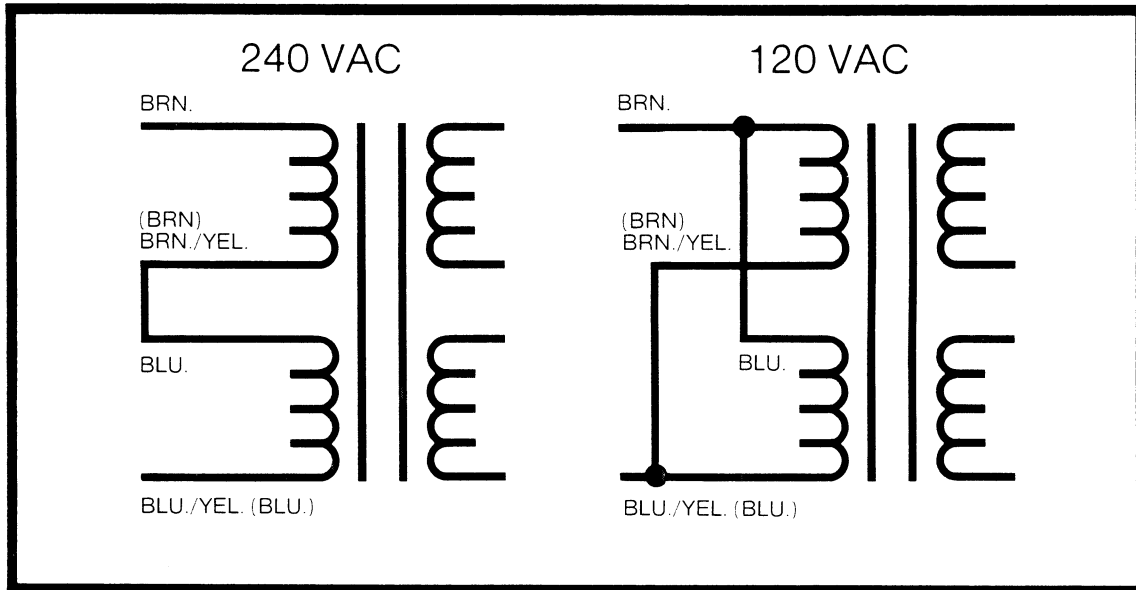

IF THE PRIMARY VOLTAGE IS CHANGED, THE LINE FUSE MUST BE CHANGED AS FOLLOWS:

120 VAC: Use 5 AMP, Type AGC
240 VAC: Use 2½ AMP, Type AGC

Phase Linear Service Department
20121 48th Ave. West
Lynnwood, WA 98036
Tel. (206) 774-8848
(206) 774-3571

prepared 10/78
revised 7/81

200 SERIES TWO POWER AMPLIFIER

SERVICE MANUAL

CONTENTS

1-0. Technical Specifications	4
2-0. Schematics and Diagrams	5
3-0. Circuit Description	10
4-0. Disassembly Procedure	11
5-0. Test Procedure	12
6-0. Troubleshooting Guide	14
7-0. Parts List	21
8-0. Service Bulletins and Supplements	22

***** CAUTION *****

THIS MANUAL IS INTENDED FOR USE ONLY BY QUALIFIED TECHNICAL SERVICE PERSONNEL. HAZARDOUS VOLTAGES MAY BE ENCOUNTERED IN THE TEST AND SERVICING OF THE 200 SERIES TWO. USE EXTREME CAUTION: READ ALL INSTRUCTIONS CAREFULLY.

1.0 Technical Specifications

Performance

POWER OUTPUT: 120 watts minimum power RMS per channel into 8 ohms from 20 Hz to 20K Hz with no more than 0.09% Total Harmonic Distortion.

CONTINUOUS POWER: 150 watts per channel into 8 ohms @ 1000 Hz; 190 watts per channel into 4 ohms @ 1000 Hz.

TYPICAL TOTAL HARMONIC DISTORTION: 0.009% at rated power into 8 ohms @ 1000 Hz; 0.009% at rated power into 4 ohms @ 1000 Hz.

INTERMODULATION DISTORTION (60 Hz: 7K Hz = 4 : 1): less than 0.09% at rated power into 8 ohms; less than 0.09% at rated power into 4 ohms.

FREQUENCY RESPONSE: 12 Hz to 40K Hz, +0 -1 dB.

SIGNAL-TO-NOISE RATIO: 110dB (IHF A-Weighted).

RESIDUAL NOISE: 120 uV (IHF A-Weighted).

DAMPING FACTOR: 1000 : 1 @ 1000 Hz.

INPUT IMPEDANCE: 32K ohms

INPUT SENSITIVITY: 1.5 Volts RMS for 120 watts @ 8 ohms.

SPEAKER IMPEDANCE: Accepts 4 ohms to 16 ohms.

SLEW RATE: Better than 15V/uS.

RISE TIME: (Small Signal) Less than 4.0 uS.

PHASE SHIFT: 0 degrees at 20 Hz, -18 degrees at 20K Hz.

Indicator

A light-emitting diode (LED) on the front panel provides power-on indication.

Protection

- A. Output Transistor Protection: electronic limiters together with power supply fuses prevent excursions into the unsafe operating region, regardless of load condition.
- B. Speaker Protection: The amplifier does not provide speaker protection from excessively high-power audio signals. External fusing of the speakers is highly recommended.

An electronically activated relay disconnects the amplifier's output to the speakers

- 1) for approximately five seconds after turn-on.
- 2) immediately after turn-off.
- 3) in the presence of DC output voltage or high-power subsonic signals.

General

POWER REQUIREMENTS: 60Hz 120V (USA & Canadian models) or 100-120/
220-240V AC, 50/60 Hz.

POWER CONSUMPTION: 600 watts (5 amps) maximum at rated output; 27 watts
(230mA) at idle.

DIMENSIONS: 19"w X 5½"h X 8 3/4"d (48.3 cm X 14 cm X 22.2cm)

WEIGHT GROSS: 16 lbs.; 7 kg.

2-0. Schematics and Diagrams.

- 2-1. Schematic: PL19, Main PCB.
- 2-2. Layout, PL19 Main PCB
- 2-3. X-ray of PL19
- 2-4. Schematic: PL31, Relay PCB
- 2-5. Layout, PL31
- 2-6. X-ray of PL31
- 2-7. Interconnect Schematic

REVISIONS				
LR	DESCRIPTION	BY	DATE	AP
B	ZONE C-3 ADDED CB 150 PF	RAC	2/23/68	
C	ZONE C-2 12K 12K 12K 12K	RAC	3/15/68	
D	CORRECTION PER AUDIT	RAC	5/1/68	

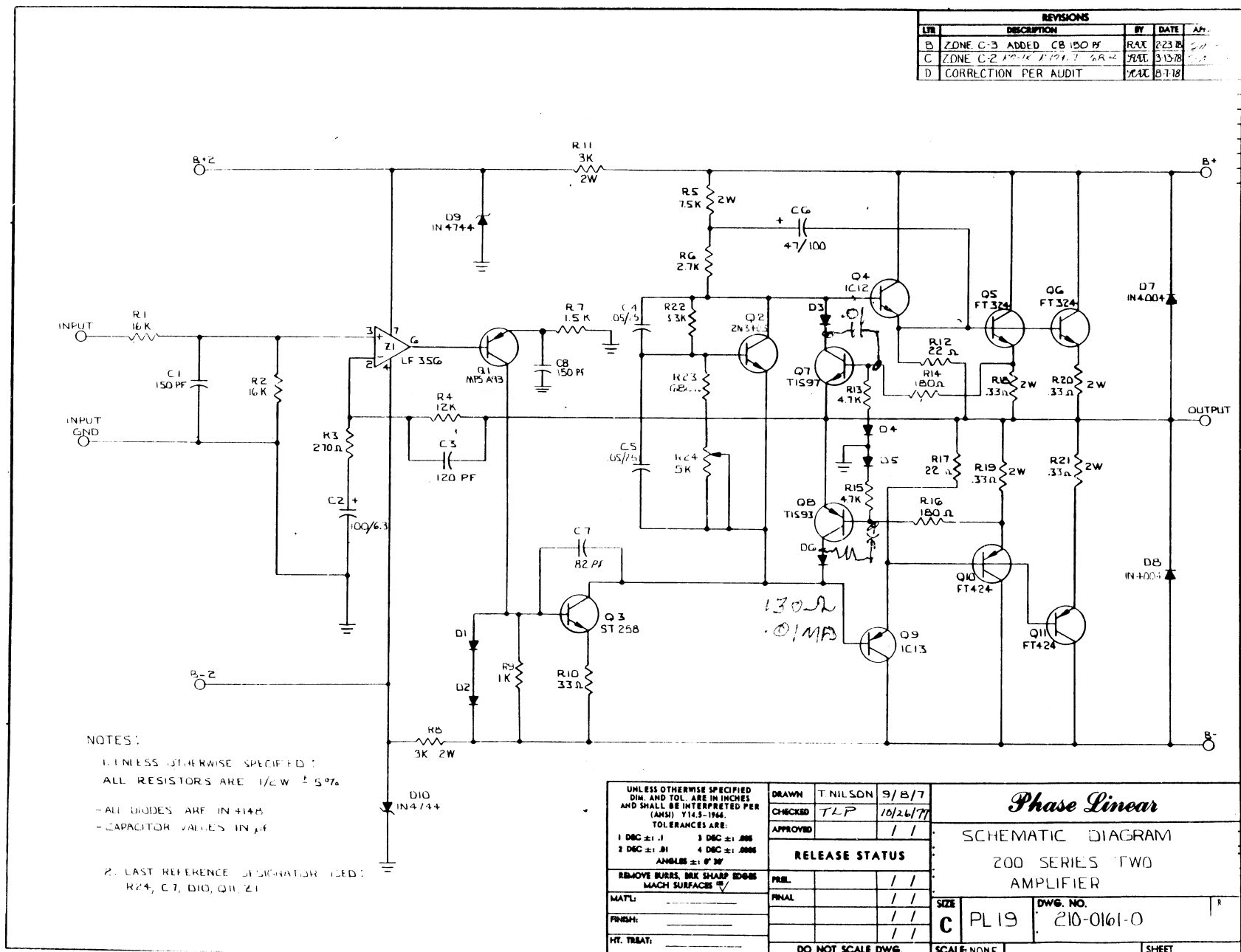

NOTES:

1. UNLESS OTHERWISE SPECIFIED:
 ALL RESISTORS ARE 1/2W ± 5%

- ALL DIODES ARE IN 4148
 - CAPACITOR VALUES IN μF

2. LAST REFERENCE DESIGNATOR USED:
 R24, C7, D10, Q11, Z1

UNLESS OTHERWISE SPECIFIED DIM. AND TOL. ARE IN INCHES AND SHALL BE INTERPRETED PER (ANSI) Y14.5-1966. TOLERANCES ARE: 1 DEC ± .1 3 DEC ± .005 2 DEC ± .01 4 DEC ± .0006 ANGLES ± 0° 30'	DRAWN	T. NILSON	9/8/77
	CHECKED	TLP	10/26/77
	APPROVED		1/1
RELEASE STATUS			
REMOVE BURS, BREAK SHARP EDGES MACH SURFACES ✓	PREL.		1/1
MATL:	FINAL		1/1
FINISH:			1/1
HT. TREAT:			1/1

<i>Phase Linear</i>	
SCHEMATIC DIAGRAM	
200 SERIES TWO AMPLIFIER	
SIZE	DWG. NO.
C PL19	210-0161-0
DO NOT SCALE DWG.	SCALE NONE
SHEET	

Diagram 2-1. Schematic: PL19, Main PCB

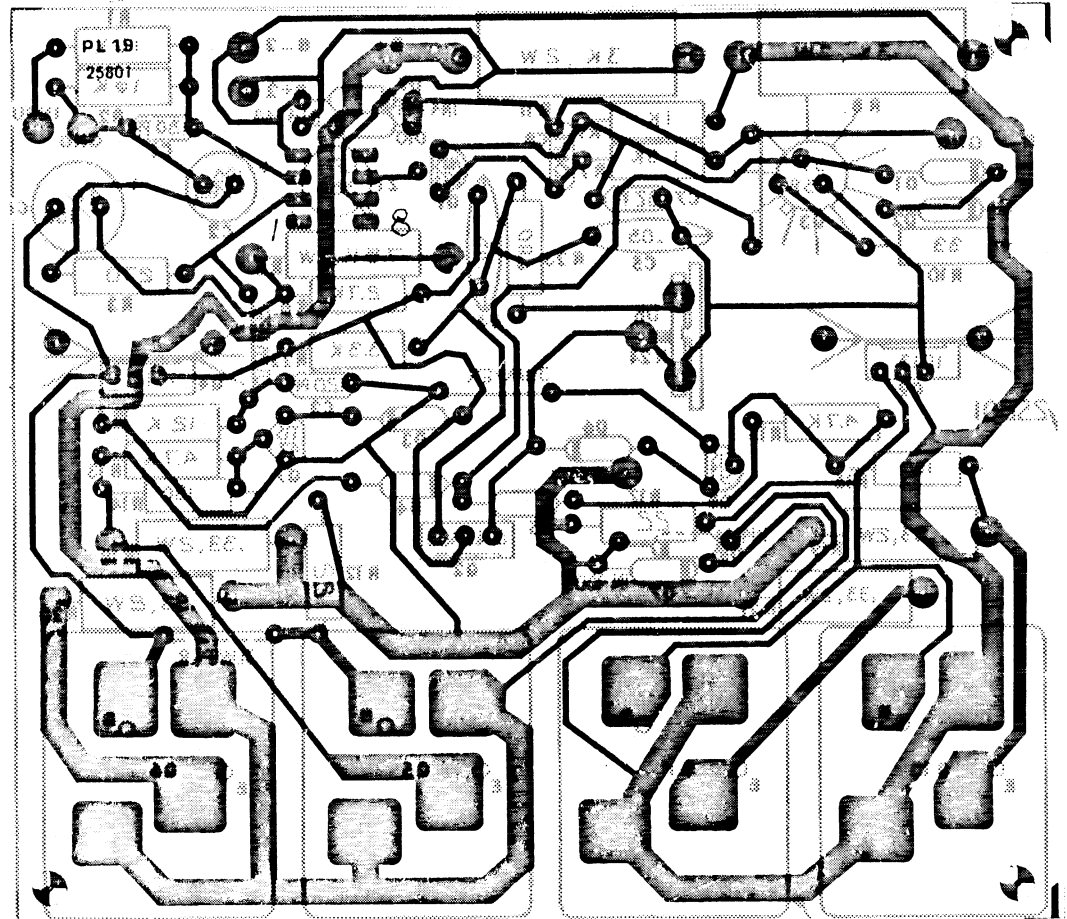
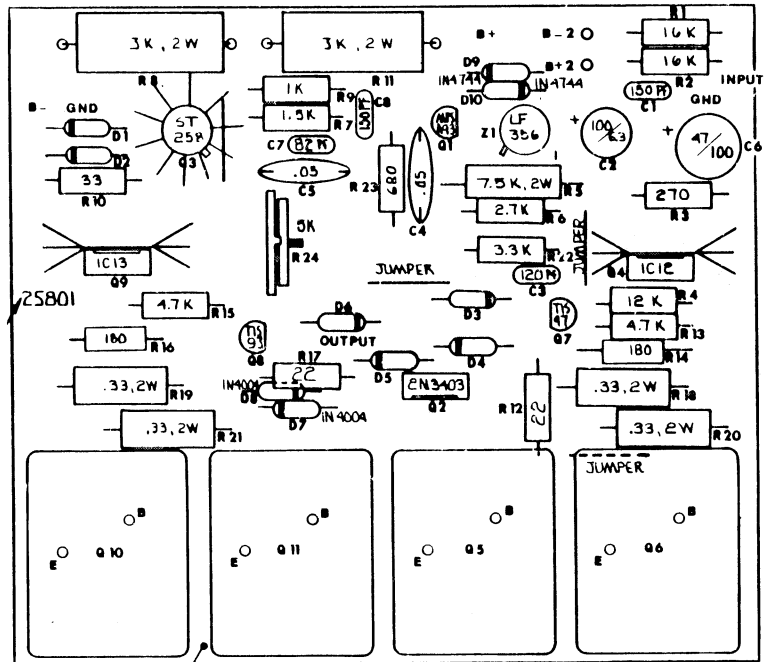

Diagram 2-2. Layout, PL19 Main PCB

Diagram 2-3. X-ray of PL19, from foil side.

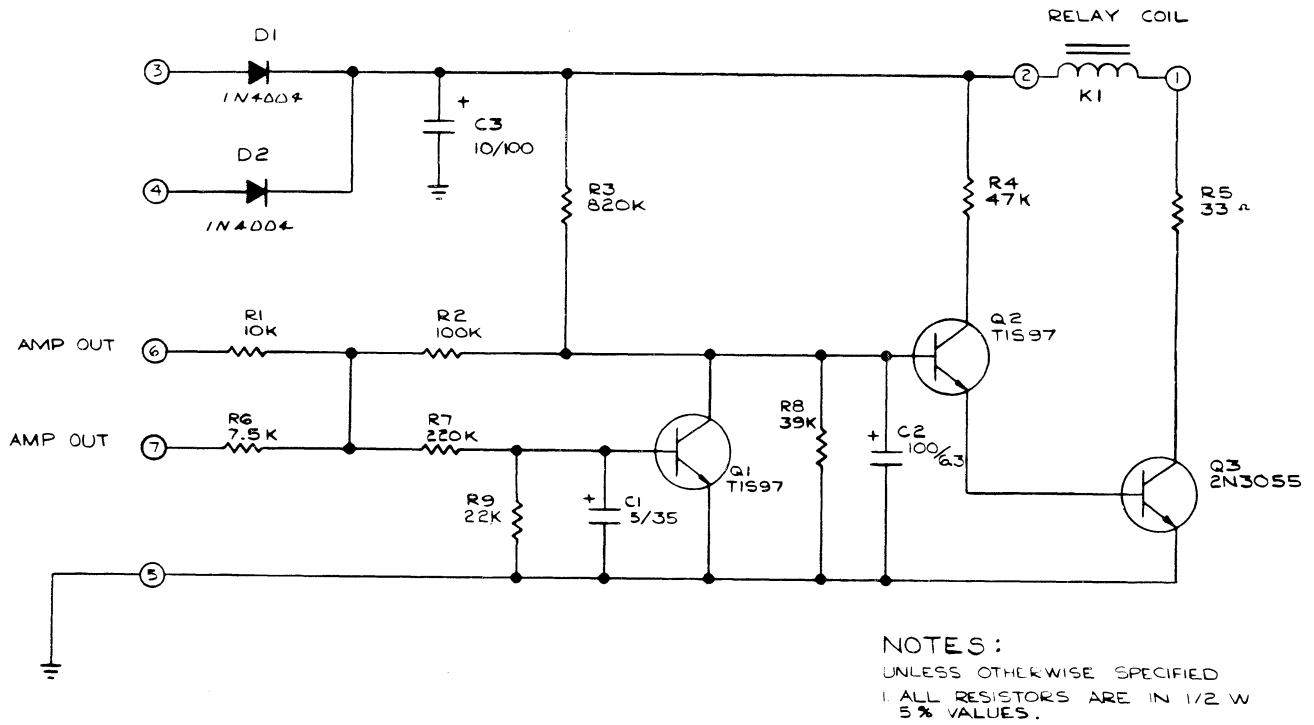

Diagram 2-4. Schematic: PL31, Relay PCB

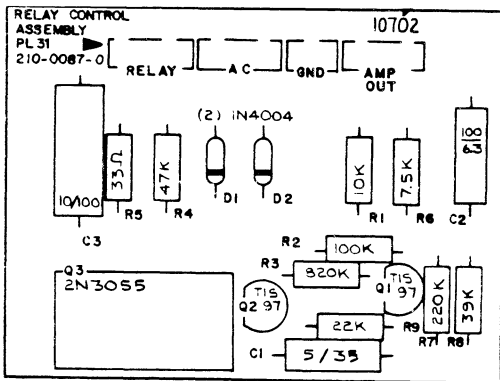

Diagram 2-5. Layout, PL31.

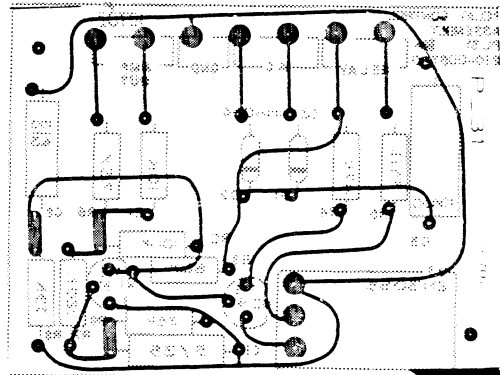

Diagram 2-6. X-ray of PL31, from foil side.

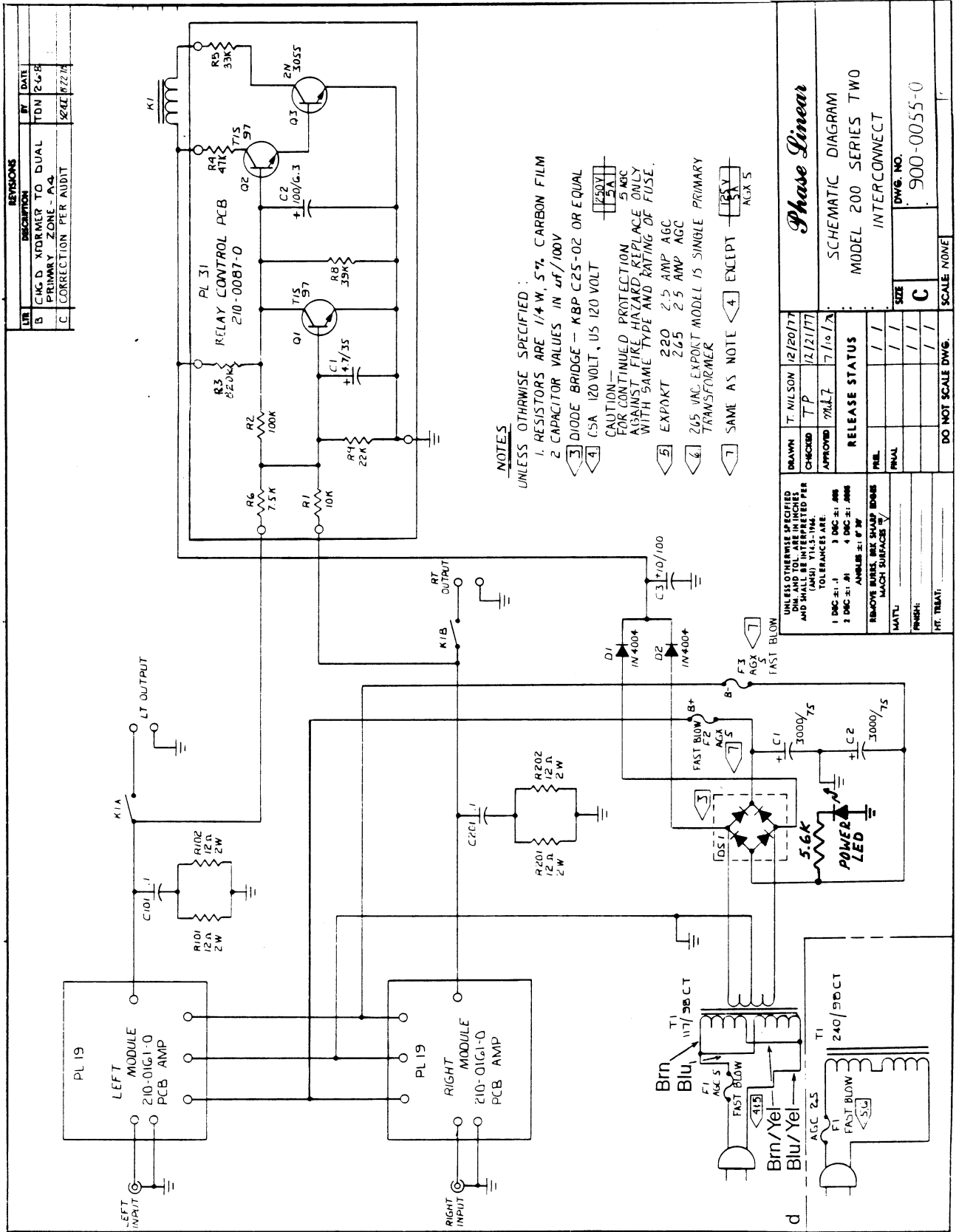

Diagram 2-7. Interconnect schematic.

3-0. 200II Circuit Description.

The Phase Linear 200 Series Two consists of two independent direct coupled linear power amplifiers combined to form a dual channel unit capable of very high power output. Please refer to the schematic diagram for the following circuit description of the individual power amplifier.

The low level input stage employs a wideband low noise FET input integrated circuit operational amplifier (Op Amp) to provide high open loop voltage gain for minimum distortion. The input signal is applied to the noninverting input of the Op Amp while the inverting input receives a portion of the final output voltage forming a negative feedback loop. A transistor functioning as a voltage level shifter couples the output signal of the Op Amp to a common emitter amplifier. The common emitter amplifier stage, biased for class A operation, is capable of swinging the full power supply voltage of 140 volts providing the final voltage gain in the amplifier.

A bootstrap arrangement is used to provide a high impedance load for the common emitter stage and at the same time increases the amount of drive current available to the positive drive transistor allowing symmetrical saturation. Control of the amplifier idle current is accomplished with a transistorized biasing circuit which regulates the bias conditions of the driver and output transistors. The bias regulator transistor is mounted on the output stage heat sink assembly to achieve proper thermal tracking and prevents the possibility of thermal runaway.

The output stage of each channel employs 4 high current, high voltage silicon power transistors arranged in a fully complementary format and biased for class B operation. Most of the required bias current is carried by the driver transistors, resulting in very high circuit efficiency. In this design, the driver transistors serve to provide current amplification of the output signal from the common emitter stage to a level required by the parallel connected output transistors.

Voltage and current levels of the output transistors are monitored continuously during amplifier operation by the built-in protection circuit. The protection circuit consists of two transistors: one operates when the amplifier output is positive and the other operates when the amplifier output is negative. If the voltage and current levels in the output transistors become excessive, the protection current entering the predriver transistors will conduct to divert drive current entering the predriver transistors thereby limiting the current flow in the output stage to a safe level.

4-0. Disassembly Procedure

4-1. For tune-up and minor servicing, remove the bottom cover plate (9 phillips screws).



4-2. To remove a module from the chassis, place the amplifier upside down with heat sinks forward.

4-2.1. Remove the four module mounting screws and kep nuts.

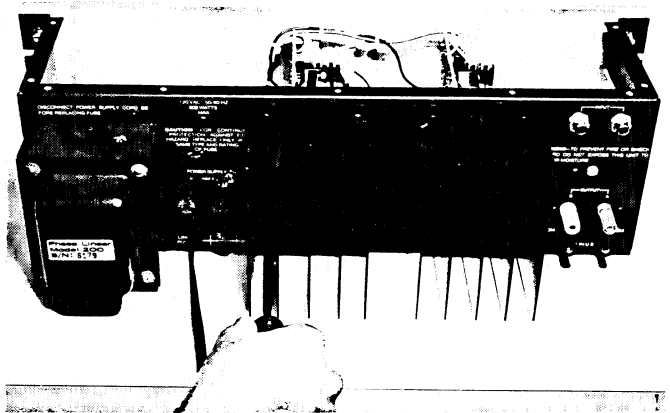

4-2.2. Carefully pull the module forward out of the chassis --do not strain the wire harness or bend the Q4 and Q5 heat sinks.

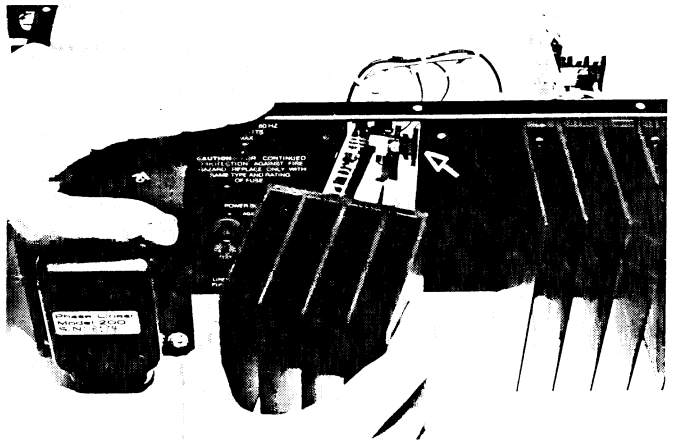

4-3. To reassemble, reverse the above procedure.

5.0. Test Procedure

Contents

- 5-1. Power supply
- 5-2. Energizing the unit
- 5-3. Output signal without load
- 5-4. Output signal with 8 ohm Load
- 5-5. Distortion
- 5-6. Offset
- 5-7. Short circuit test
- 5-8. Output relay test

Necessary equipment:

Low distortion audio signal generator
VOM or DVM
High impedance scope
250 watt 8 ohm load resistor

- 5-1. Power supply. Before plugging in the AC line cord on the 200, check all fuses: verify AGX-5 fuses for the supply and AGC-5 for the line fuse. (AGC-2.5 for 240 volt operation).

CAUTION: If any fuse is discovered blown, do not energize the unit, even after replacing the blown fuse(s). Follow the procedure in section 6-1 to properly energize the unit without causing possible further damage to the output stage.

- 5-2. Energizing the unit. Plug the line cord into a variable line transformer and slowly turn it up to 117 VAC or 230 VAC as required. If a line transformer is not available, plug the line cord directly into a working AC outlet of proper line voltage. Verify that the LED power indicator lights up immediately.
- 5-3. Output signal with no load. Monitor the left channel output with the scope and AC voltmeter. DO NOT connect any other load to the outputs at this time. Drive the left channel input with a 2K Hz sine wave until the output wave form is well into clipping. Verify that the clipping is symmetrical. Repeat the above with the right channel.
- 5-4. Output with 8 ohm load. Connect an 8 ohm 250 watt load resistor to the left channel output terminals and monitor the left channel output. Apply a 2K Hz signal to the Left channel input and verify at least 31V RMS output before clipping. Repeat the above at 20Hz, 200 Hz, and 20K Hz for both left and right channels.
- 5-5. Distortion. Monitor the left channel output with a THD analyzer. With an 8 ohm load connected also to the left channel output, drive the left channel to 31V RMS and verify a THD of 0.09% or less. Repeat this procedure with the right channel. This same procedure may also used to test for IM distortion of 0.09% or less.

NOTE: It may be necessary to use the high filter in the THD analyzer if it is so equipped.

- 5-6. Offset. Measure across the output terminals of each channel for presence of DC voltage and verify ± 10 mV or less with NO inputs connected to the unit.
- 5-7. Short circuit test. Drive the left channel with a 200 Hz signal to an output level of 31V RMS. Now short the output terminals with a jumper wire for 2 to 4 seconds. Remove the jumper and verify that the amplifier resumes normal operation. Repeat the above with the right channel.
- 5-8. Output relay test. Drive the left channel into clipping with a 1 Hz to 10 Hz signal (with or without a load resistor connected to the output terminals) and verify that the output signal is removed almost immediately; this should be accompanied by a distinct clicking sound as the output relay opens. Turn down or remove the input signal and verify that the output relay closes in 2 to 4 seconds, restoring signal to the output terminals. Repeat this procedure with the right channel.

6-0. TROUBLESHOOTING GUIDE

CONTENTS

- 6-1. Power supply malfunction
- 6-2. Unit will not energize properly
- 6-3. Output malfunction--no load
- 6-4. Output malfunction into a load
- 6-5. Excessive distortion/Bias adjustment
- 6-6. Excessive offset
- 6-7. Protection circuit malfunction
- 6-8. Output relay malfunction

NOTE: Most transistors and diodes in the 200II can be checked in circuit using an ohmmeter on the RX1, RX10 or 2K scale. With the 200II power OFF, measure the forward-biased resistance of the particular diode or transistor junction and verify a reading of 400 to 700 ohms on a typical DVM for a good device. Actual readings on good devices will vary from meter to meter, and some meters do not have sufficient test voltage to turn on a semiconductor. Nevertheless the shorted or open device is usually revealed quickly using this in-circuit method.

CAUTION: BEFORE MAKING ANY MEASUREMENTS INTERNAL TO THE 200II, UNLESS OTHERWISE SPECIFIED, BE SURE THAT THE LINE CORD IS UNPLUGGED AND THE POWER SUPPLY CAPACITORS ARE DISCHARGED--WAIT AT LEAST 5 MINUTES AFTER UNPLUGGING THE AMPLIFIER TO ENSURE THAT THESE CAPACITORS ARE DISCHARGED. USE EXTREME CAUTION WHEN TAKING ANY MEASUREMENTS INTERNAL TO THE 200II WITH POWER ON--HAZARDOUS VOLTAGES ARE PRESENT. ONLY QUALIFIED PERSONNEL WITH PROPERLY INSULATED AND PROTECTED EQUIPMENT SHOULD ATTEMPT SERVICING OF THE 200II WITH POWER ON.

6-1. POWER SUPPLY MALFUNCTION

- 6-1.1. Blown supply fuse. If any of the supply fuses are found blown, there is a high probability that one or more of the output transistors is defective, especially if the blown fuse appears blackened or silvered (indicating large current surge).

CAUTION: Do not replace the fuse(s) and energize the unit

at this point since this may cause further damage to the output stage. First perform the following test to check for defective output transistors.

6-1.2. Checking for shorted outputs. Be sure that the AC line cord of the 200II is unplugged, then follow the disassembly procedure, section 4-0. For the NPN outputs (FT324, 2SD555) place the negative probe of an ohmmeter on the collector buss of the output transistors. Touch the positive probe to any one of the output emitters in that bank. For the PNP outputs (FT424, 2SB600) place the positive probe of an ohmmeter on the collector buss of the output transistors. Touch the negative probe to any one of the output emitters in the bank. If any one of the transistors in that bank are shorted, the meter will display a very low reading, usually less than an ohm. If none of the outputs are shorted, the meter will display a typical reading for a forward biased diode (since measurement is essentially across flyback diodes, D7 and D8), usually 400 to 700 ohms depending on the DVM in use. Repeat the above for each remaining bank of transistors. Refer to 6-1.3 for isolation of a defective output transistor.

6-1.3. Isolating defective outputs. To isolate the defective output(s) in a bank which indicates a short, switch the ohmmeter to the lowest scale (RX1 or RX200 ohms). Touch the proper probe (negative for NPN, positive for PNP) to the collector buss as in 6-1.2. and touch the other probe to each output emitter in that bank. One reading will be significantly lower (about 0.6 ohm) than the other, which indicates that that particular output transistor is shorted. Remove the outputs and check each one individually. Replace the defective output(s) and repeat the above procedure until no short is indicated.

IMPORTANT: Whenever any output transistor has been replaced it is necessary to perform step 6-1.4. to verify proper current sharing of all output transistors.

6-1.4. Current sharing test. This test is necessary to verify that ALL output transistors are operating properly, ensuring a permanent repair. Although the amplifier will probably meet all specs without all outputs operational, increased current loading of the remaining outputs will result in a significant reduction in reliability.

- a) With an 8 ohm load connected to the output terminals of the left channel, drive the left input with a 200 Hz signal to obtain 31 V RMS output. Turn the line voltage down to 75 VAC.
- b) Using a DC voltmeter, measure the voltage drop across the emitter resistors in each bank. Verify that there is between 240 - 300 mV DC across each each resistor.
- c) Replace any output transistor whose emitter resistor reading varies more than +10% from the average reading in that bank. Verify first that the emitter resistor itself is not damaged. Repeat for the right channel.

6-1.5. Blown line fuse.

- a) Check for shorted transformer.
- b) Check for shorted power supply capacitor.
- c) Check for shorted bridge rectifier diode(s).

6-2. UNIT WILL NOT ENERGIZE PROPERLY.

6-2.1. Unit blows line fuse at turn-on. Refer to section 6-1.5 for power supply troubleshooting procedure.

6-2.2. Unit blows supply fuse(s) at turn-on. This indicates output transistor failure; refer to section 6-1.1.

6-2.3. Output relay fails to engage. Refer to section 6-8 for relay troubleshooting procedure.

6-3. OUTPUT MALFUNCTION, NO LOAD.

6-3.1. No output, one or both channels.

- a) Check for blown supply fuse or line fuse. Refer to section 6-1.
- b) With power off, check all transistors and diodes in circuit as described in section 6-0.
- c) Drive the inputs with 1 volt at 2K Hz; energize the unit and check for signal at pin 6 of Z1 in each channel. If Z1 has latched up to the front end supply (+15 V), replace Z1.

Note: Due to the common fusing of the modules (including the front end IC), if the output stage and front end IC Z1 has failed in one channel, there is a chance that the op amp in the other channel has failed also. Check this and R7 and replace as necessary.

- d) Excessive current drawn when voltage applied to line cord.
 - check the bias transistor carefully for open junctions. Replace as necessary. If the bias transistor measures good but the amp still draws current, then short the bias transistor emitter to collector with a jumper wire. If the amp ceases to draw excess line current then replace the bias transistor.
 - check the output and driver transistors
- e) Isolate the protection circuit as outlined in 6-3.3a and retest.
- f) Check for loose, worn or dirty input jacks.

6-3.2. Asymmetrical clipping.

- a) Verify matched power supply readings at the power supply filter capacitors. There should be no more than 2 volts difference between positive and negative supply readings.
- b) Possible defective predriver Q4 or Q9; replace as necessary.
- c) See 6-3.3.

6-3.3. Truncated or asymmetrical output.

- a) Possible faulty protection circuit: disconnect one end of D3 and D6, then recheck output wave form. If the problem is now removed, check and replace D3, D6, D5, Q7 and Q8 as necessary.
- b) Possible defective predriver. Check Q4 and Q9.
- c) Possible defective Q3; check and replace as necessary.
- d) Possible defective bootstrap cap C6. Replace C6.

6-3.4. Oscillations.

- a) Check RC networks located at the relay terminals.

- b) Replace predrivers Q4 and Q9 as necessary.
- c) Install "slow down" caps, 150 to 270 pf on the appropriate predriver, base to collector. The amp should be stable without these so install these caps only as a last resort.
- d) Check the output transistor insulators: if these are the silicone rubber type, there is a possibility of parasitic oscillations caused by the output transistor casing biting through the insulator as a result of overtightening. It is recommended that if this problem exists the insulators be replaced with the mica type lubricated with thermal compound.
- e) If oscillations (bursts) occur just before rated output, be sure that the line voltage at the line plug is between 117 and 120 VAC.

6-4. OUTPUT MALFUNCTION INTO A LOAD.

6-4.1. Unit will not deliver 31 VRMS into an 8 ohm load.

- a) Check for line or variac voltage sag; voltage at the line plug must be at least 117 VAC while delivering full output.

6-4.2. Asymmetrical clipping or truncation.

- a) Check the protection circuit as outlined in 6-3.3 and recheck.
- b) Possible defective driver Q4 or Q9.
- c) Check for balanced power supply at the main filter caps while driving a load. If the voltages differ by more than 2 volts, replace the cap which reads low.
- d) Check for defective (burned) emitter resistors in the output stage. Perform 6-1.4.

6-5. Excessive Distortion; BIAS ADJUSTMENT

6-5.1. Improper bias setting: check and adjust as follows.

- a) Allow 5 minutes warm-up time.
- b) Remove all input and output connections, then measure the DC voltage drop across R12 or R17.

Verify approximately 0.4 VDC, +0.1 V. Adjust bias pot R24 as necessary.

6-5.2. Excessive THD Measurement.

- a) Excessive crossover distortion: possible shorted bias transistor; check and replace as necessary.
- b) Defective protection circuit: see section 6-3.3.
- c) THD analyzer interface problems:
 - activate the 80K Hz filter on the analyzer if it is so equipped; repeat the THD measurement.
 - examine the test bench grounding system for possible ground loops. Ground the analyzer directly to the 200II output ground, not to the load, scope or meter grounds.

6-6. EXCESSIVE OFFSET

- a) Replace Z1.
- b) Verify +15 VDC across D9 and D10; replace if necessary.
- c) Replace C2 (100mf 6.8V)

Note: refer to section 6-3.1c for further information.

6-7. PROTECTION CIRCUIT MALFUNCTION

6-7.1. Supply fuses open when amplifier is shorted. This indicates that the protection circuit is not shunting drive current properly.

- a) Check Q7, Q8, D3, D6.
- b) Check R14, R16, R18, R19.
- c) Perform current sharing test 6-1.4 to determine if the current sensing transistors for the protection circuit (Q5, Q10) are open.

6-8. OUTPUT RELAY MALFUNCTION.

6-8.1. Output relay will not open with low frequency signal.

- a) Check Q1, C4 on the relay control PCB PL31.
- b) Check wiring connections from PL31.

6-8.2. Output relay opens prematurely or intermittently.

- a) Check for excessive offset: see 6-6.
- b) Check Q2, Q3, and C5 on PL31.

6-8.3. Output relay will not close after unit is energized.

- a) Check for excessive offset at the relay terminals. See section 6-6.
- b) Check Q2, Q3 and C5 on PL31.
- c) Check for defective output transistors as outlined in section 6-1.1 and 6-1.3.
- d) Visually inspect the relay and verify proper operation of the armature. The armature may become dislodged as a result of rough handling in shipment, and will not completely close though there is sufficient voltage to the coil. If such is the case, simply reposition the armature to ensure proper operation.

7-0. 200II Parts List

TRANSISTORS:

FT324,2SD555,2SD424...126-0068-0
FT424,2SB600,2SB554...126-0069-0
1C12.....126-0031-0
1C13.....126-0032-0
TIS 93.....126-0009-0
TIS 97.....126-0020-0
2N3403.....126-0018-0
ST258.....126-0035-0
MPS A93.....126-0028-0
2N3055.....126-0025-0

INTEGRATED CIRCUITS:

LF356.....126-0051-0

DIODES:

1N4148.....126-0002-0
1N4004.....126-0003-0
1N4744.....126-0064-0
LED, amber.....126-0065-0
S25A20 Bridge Rect....126-0001-0

CAPACITORS:

3000/75v elec.....127-0048-0
47/35v elec.....127-0032-0
100/6.3v elec.....127-0033-0
5/35v elec.....127-0037-0
10/100v elec.....127-0093-0
100/10v elec.....127-0022-0
.05/25v cer.....127-0007-0

RESISTORS:

3K/5w.....128-0378-0
7.5K2w.....128-0348-0
12/2w.....128-0357-0
.33/2w.....128-0350-0

POTENTIOMETERS:

5K Trim (R24).....129-0001-0

TRANSFORMER:

117-220v Pri/98v Sec.125-0027-0

PRINTED CIRCUIT BOARDS:

PL19 Drive.....210-0161-0
PL31 Relay,Control...210-0087-0

FRONT PANEL ACCESSORIES:

Handle, Rack-mount...142-0027-0
Handle Ferrule.....143-0015-0

METALWORK:

Front Panel.....220-0042-0
Top Cover.....141-0126-0
Bottom Cover.....141-0127-0
Chassis.....220-0041-0
Heatsink.....142-0017-0

NOTE: When ordering replacement parts please specify model and serial number of unit.

USE ONLY REPLACEMENT PARTS ISSUED OR AUTHORIZED BY THE FACTORY SERVICE DEPARTMENT. A UNIT WILL NOT BE CONSIDERED UNDER FACTORY WARRANTY IF UN-AUTHORIZED SUBSTITUTE REPLACEMENT PARTS HAVE BEEN INSTALLED.

8-0. Service Bulletins and Supplements.

This section of the 200II Service Manual is reserved for the inclusion of any service bulletins, troubleshooting or other supplements which apply to the 200II.

SERVICE BULLETIN

SUBJECT: 200 Series II complimentary output transistors.

We are currently using two different brands of complimentary pair output transistors in the 200 Series II. These are the FT324-PNP and FT424-PNP (made by Fairchild) and the 2SD555-NPN and 2SB600-NPN (made by NEC-Nippon Electric Co.). A few of the early 200 II's were built with Toshiba output transistors (used by SAE) which we do not stock.

As in our other power amps, different brands should not be mixed in the same channel so please be sure to specify which brand you need when ordering these transistors. If you receive a 200 II with defective Toshiba output transistors it will be necessary to change the entire channel's worth with currently available Fairchild or NEC devices.

SERVICE BULLETIN
122778

SUBJECT: 200 SERIES TWO OUTPUT TRANSISTORS

We have found that some early production models of the 200 Series Two amplifiers which utilize Fairchild output transistors (FT342 and FT424) may exhibit thermal overheating or thermal runaway.

If a 200 Series Two is using Fairchild outputs, resistors R12 and R17 (68 ohm, ½-watt) must be changed to "22 ohm, ½-watt". This has since been a permanent production change on all 200 Series Two PC driver boards regardless of output types being used.

If you have any problems or questions feel free to contact the factory service department.

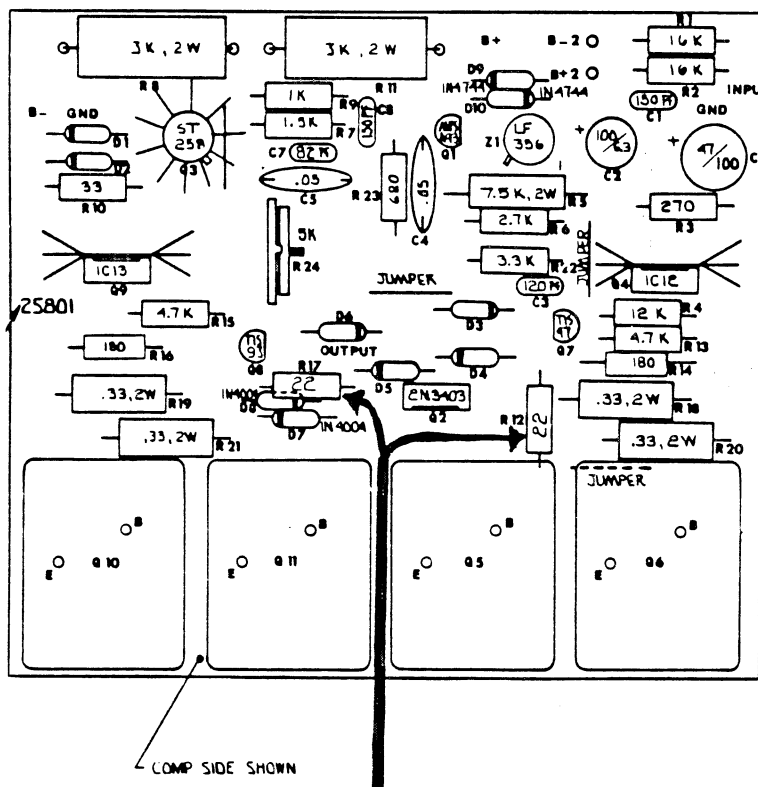

SERVICE BULLETIN

SUBJECT: 200 Series II trimpot & bias adjustment.

The early 200II was assembled with a 1K ohm (green) bias trim pot. We have found that in some amplifiers the 1K trim pot does not allow adequate adjustment of the output transistor bias voltage which may cause excessive idling temperature. When idling, the 200II heatsinks should be cool to the touch.

We are now using a 5K ohm (red) bias trim pot which allows a much greater range of bias adjustment. Bias voltage should be carefully measured across either R12 or R17 and should be set at approximately 400mv DC. After a five minute warm up period. This will stabilize the idling temperature. 5K trim pots are available from the factory service dept. on request. The part number for this part is 129-0001-0.